

SECTION VI

2021

ASME Boiler and
Pressure Vessel Code
An International Code

**Recommended Rules for
the Care and Operation
of Heating Boilers**

Markings such as “ASME,” “ASME Standard,” or any other marking including “ASME,” ASME logos, or the ASME Single Certification Mark shall not be used on any item that is not constructed in accordance with all of the applicable requirements of the Code or Standard. Use of the ASME Single Certification Mark requires formal ASME certification; if no certification program is available, such ASME markings may not be used. (For Certification and Accreditation Programs, see <https://www.asme.org/certification-accreditation>.)

Items produced by parties not formally possessing an ASME Certificate may not be described, either explicitly or implicitly, as ASME certified or approved in any code forms or other document.

AN INTERNATIONAL CODE

2021 ASME Boiler & Pressure Vessel Code

2021 Edition

July 1, 2021

VI

RECOMMENDED RULES FOR THE CARE AND OPERATION OF HEATING BOILERS

ASME Boiler and Pressure Vessel Committee
on Heating Boilers



The American Society of
Mechanical Engineers

Two Park Avenue • New York, NY • 10016 USA

Date of Issuance: July 1, 2021

This international code or standard was developed under procedures accredited as meeting the criteria for American National Standards and it is an American National Standard. The Standards Committee that approved the code or standard was balanced to assure that individuals from competent and concerned interests have had an opportunity to participate. The proposed code or standard was made available for public review and comment that provides an opportunity for additional public input from industry, academia, regulatory agencies, and the public-at-large.

ASME does not “approve,” “certify,” “rate,” or “endorse” any item, construction, proprietary device, or activity.

ASME does not take any position with respect to the validity of any patent rights asserted in connection with any items mentioned in this document, and does not undertake to insure anyone utilizing a standard against liability for infringement of any applicable letters patent, nor assume any such liability. Users of a code or standard are expressly advised that determination of the validity of any such patent rights, and the risk of infringement of such rights, is entirely their own responsibility.

Participation by federal agency representative(s) or person(s) affiliated with industry is not to be interpreted as government or industry endorsement of this code or standard.

ASME accepts responsibility for only those interpretations of this document issued in accordance with the established ASME procedures and policies, which precludes the issuance of interpretations by individuals.

The endnotes and preamble in this document (if any) are part of this American National Standard.



ASME Collective Membership Mark



ASME Single Certification Mark

"ASME" and the above ASME symbols are registered trademarks of The American Society of Mechanical Engineers.

No part of this document may be reproduced in any form, in an electronic retrieval system or otherwise, without the prior written permission of the publisher.

Library of Congress Catalog Card Number: 56-3934
Printed in the United States of America

Adopted by the Council of The American Society of Mechanical Engineers, 1914; latest edition 2021.

The American Society of Mechanical Engineers
Two Park Avenue, New York, NY 10016-5990

Copyright © 2021 by
THE AMERICAN SOCIETY OF MECHANICAL ENGINEERS
All rights reserved

TABLE OF CONTENTS

List of Sections	vi
Foreword	viii
Statement of Policy on the Use of the ASME Single Certification Mark and Code Authorization in Advertising	x
Statement of Policy on the Use of ASME Marking to Identify Manufactured Items	x
Submittal of Technical Inquiries to the Boiler and Pressure Vessel Standards Committees	xi
Personnel	xiv
Summary of Changes	xxxv
List of Changes in Record Number Order	xxxvi
Cross-Referencing and Stylistic Changes in the Boiler and Pressure Vessel Code	xxxvii
Article 1	Introduction
	1
Article 2	Glossary
	2
Article 3	Types of Boilers
	6
3.1	Classification
	6
3.2	ASME Certification Mark
	6
3.3	Method of Manufacture
	6
3.4	Category
	7
Article 4	Fuels and Fuel-Burning Equipment
	11
4.1	Types of Fuels
	11
4.2	Fuel-Burning Equipment
	13
Article 5	Boiler Room Facilities and Installation
	15
5.1	General
	15
5.2	Lighting
	15
5.3	Ventilation and Combustion Air
	15
5.4	Clearances
	16
5.5	Fire Protection
	16
5.6	Electrical Supply
	16
5.7	Fuel Supply
	16
5.8	Chimney or Vent
	16
5.9	Piping — Water and Drain Connections
	16
5.10	Safety
	24
5.11	Housekeeping
	25
5.12	Posting of Certificates and/or Licenses
	25
5.13	Record Keeping, Logs, Etc.
	25
Article 6	Overpressure Protection
	26
6.1	Pressure Relief Valves
	26
6.2	Pressure Relief Valve Requirements
	26
6.3	Mounting
	27

6.4	Pressure Relief Valve Discharge Piping	28
6.5	Temperature and Pressure Safety Relief Valves	28
6.6	Valve Replacement	28
6.7	Try-Lever Test for Safety Valves (Steam Boilers)	28
6.8	Try-Lever Test for Safety Relief Valves (Water Boilers)	30
Article 7	System Accessories	31
7.1	Steam Boilers	31
7.2	Hot Water Boilers	32
Article 8	Controls and Instrumentation	34
8.1	Low-Water Fuel Cutoffs and Water Feeders	34
8.2	Pressure Gauge	36
8.3	Controls	36
8.4	Steam Heating Boilers	37
8.5	Hot Water Heating Boilers	38
Article 9	Operation and Maintenance of Steam Boilers	40
9.1	Starting a New Boiler and Heating System	40
9.2	Starting a Boiler After Layup (Single-Boiler Installation)	41
9.3	Condensation	41
9.4	Cutting in an Additional Boiler	41
9.5	Operation	42
9.6	Removal of Boiler From Service	43
9.7	Maintenance	43
Article 10	Operation and Maintenance — Hot Water Boilers and Hot Water Heating Boilers	46
10.1	Starting a New Boiler and Heating System	46
10.2	Starting a Boiler After Layup (Single-Boiler Installation)	46
10.3	Condensation	47
10.4	Cutting in an Additional Boiler	47
10.5	Operation	47
10.6	Removal of Boiler From Service	47
10.7	Maintenance	48
Article 11	Inspections of Installed Boilers	51
11.1	Periodic Inspection of Boilers	51
11.2	Inspection of the Boiler by the Inspector	51
Article 12	Boiler Repairs	52
12.1	Precaution	52
12.2	Notification	52
12.3	Welding Requirements	52
12.4	Safety	52
Article 13	Water Treatment	53
13.1	Scope	53
13.2	Considerations	53
13.3	Water Treatment Specialists	53
13.4	Local Ordinances	53
13.5	Potential Boiler Water Problems	53

13.6	Blowdown (Steam Boilers)	54
13.7	Chemical Feeders	54
13.8	Procedures	54
Article 14	Treatment of Laid-Up Boilers	55
14.1	General	55
14.2	Dry Method	55
14.3	Wet Method	55
Mandatory Appendix I	Periodic Testing and Maintenance	56
I-1	Inspection and Maintenance Program	56
I-2	Responsibilities of Personnel	56
Figures		
3.3.1.1.1-1	Horizontal Tube, Brick-Set	8
3.3.1.1.2-1	Gas Flow Patterns of Scotch-Type Boilers	8
3.3.1.1.3-1	Type C Firebox Boiler	9
3.3.1.1.3-2	Three-Pass Firebox Boiler	9
3.3.1.1.4-1	Vertical Firetube Boiler	10
3.3.2.1-1	Horizontal Sectional Cast Iron Boiler	10
3.3.2.1-2	Vertical Sectional Cast Iron Boiler	10
5.9.1-1	Single Hot Water Heating Boiler — Acceptable Piping Installation	17
5.9.1-2	Hot Water Heating Boilers in Battery — Acceptable Piping Installation	18
5.9.1-3	Single Steam Boilers — Acceptable Piping Installation	19
5.9.1-4	Steam Boilers in Battery — Pumped Return — Acceptable Piping Installation	20
5.9.1-5	Steam Boilers in Battery — Gravity Return — Acceptable Piping Installation	21
5.9.8-1	Modules Connected With Parallel Piping	24
5.9.8-2	Modules Connected With Primary–Secondary Piping	24
6.1.1-1	Official Certification Mark	26
6.1.2-1	Safety Valve	27
6.1.3-1	Safety Relief Valve	27
6.4.1-1	Safety Relief Valve Discharge Pipe	29
7.1.1-1	Thermostatic Trap	31
7.1.1-2	Float Trap	32
7.1.1-3	Float and Thermostatic Trap	32
7.1.1-4	Bucket Trap With Trap Closed	32
7.1.2.3-1	Typical Return Loop	33
8.1.1-1	Float-Type Low-Water Cutoff	34
8.1.2-1	Probe-Type Low-Water Cutoff	35
I-1-1	Exhibit A	57
I-1-2	Exhibit B	59
Table		
5.9.5-1	Size of Bottom Blowoff Piping, Valves, and Cocks	22

LIST OF SECTIONS

SECTIONS

- I Rules for Construction of Power Boilers
- II Materials
 - Part A — Ferrous Material Specifications
 - Part B — Nonferrous Material Specifications
 - Part C — Specifications for Welding Rods, Electrodes, and Filler Metals
 - Part D — Properties (Customary)
 - Part D — Properties (Metric)
- III Rules for Construction of Nuclear Facility Components
 - Subsection NCA — General Requirements for Division 1 and Division 2
 - Appendices
 - Division 1
 - Subsection NB — Class 1 Components
 - Subsection NCD — Class 2 and Class 3 Components*
 - Subsection NE — Class MC Components
 - Subsection NF — Supports
 - Subsection NG — Core Support Structures
 - Division 2 — Code for Concrete Containments
 - Division 3 — Containment Systems for Transportation and Storage of Spent Nuclear Fuel and High-Level Radioactive Material
 - Division 5 — High Temperature Reactors
- IV Rules for Construction of Heating Boilers
- V Nondestructive Examination
- VI Recommended Rules for the Care and Operation of Heating Boilers
- VII Recommended Guidelines for the Care of Power Boilers
- VIII Rules for Construction of Pressure Vessels
 - Division 1
 - Division 2 — Alternative Rules
 - Division 3 — Alternative Rules for Construction of High Pressure Vessels
- IX Welding, Brazing, and Fusing Qualifications
- X Fiber-Reinforced Plastic Pressure Vessels
- XI Rules for Inservice Inspection of Nuclear Power Plant Components
 - Division 1 — Rules for Inspection and Testing of Components of Light-Water-Cooled Plants
 - Division 2 — Requirements for Reliability and Integrity Management (RIM) Programs for Nuclear Power Plants
- XII Rules for Construction and Continued Service of Transport Tanks
- XIII Rules for Overpressure Protection

* In the 2021 Edition, Subsections NC and ND have been incorporated into one publication, Subsection NCD (BPVC.III.1.NCD), Class 2 and Class 3 Components.

INTERPRETATIONS

Interpretations are issued in real time in ASME's Interpretations Database at <http://go.asme.org/Interpretations>. Historical BPVC interpretations may also be found in the Database.

CODE CASES

The Boiler and Pressure Vessel Code committees meet regularly to consider proposed additions and revisions to the Code and to formulate Cases to clarify the intent of existing requirements or provide, when the need is urgent, rules for materials or constructions not covered by existing Code rules. Those Cases that have been adopted will appear in the appropriate 2021 Code Cases book: "Boilers and Pressure Vessels" or "Nuclear Components." Each Code Cases book is updated with seven Supplements. Supplements will be sent or made available automatically to the purchasers of the Code Cases books up to the publication of the 2023 Code. Annulments of Code Cases become effective six months after the first announcement of the annulment in a Code Case Supplement or Edition of the appropriate Code Case book. Code Case users can check the current status of any Code Case at <http://go.asme.org/BPVCCDatabase>. Code Case users can also view an index of the complete list of Boiler and Pressure Vessel Code Cases and Nuclear Code Cases at <http://go.asme.org/BPVCC>.

FOREWORD*

In 1911, The American Society of Mechanical Engineers established the Boiler and Pressure Vessel Committee to formulate standard rules for the construction of steam boilers and other pressure vessels. In 2009, the Boiler and Pressure Vessel Committee was superseded by the following committees:

- (a) Committee on Power Boilers (I)
- (b) Committee on Materials (II)
- (c) Committee on Construction of Nuclear Facility Components (III)
- (d) Committee on Heating Boilers (IV)
- (e) Committee on Nondestructive Examination (V)
- (f) Committee on Pressure Vessels (VIII)
- (g) Committee on Welding, Brazing, and Fusing (IX)
- (h) Committee on Fiber-Reinforced Plastic Pressure Vessels (X)
- (i) Committee on Nuclear Inservice Inspection (XI)
- (j) Committee on Transport Tanks (XII)
- (k) Committee on Overpressure Protection (XIII)
- (l) Technical Oversight Management Committee (TOMC)

Where reference is made to “the Committee” in this Foreword, each of these committees is included individually and collectively.

The Committee’s function is to establish rules of safety relating to pressure integrity, which govern the construction** of boilers, pressure vessels, transport tanks, and nuclear components, and the inservice inspection of nuclear components and transport tanks. The Committee also interprets these rules when questions arise regarding their intent. The technical consistency of the Sections of the Code and coordination of standards development activities of the Committees is supported and guided by the Technical Oversight Management Committee. This Code does not address other safety issues relating to the construction of boilers, pressure vessels, transport tanks, or nuclear components, or the inservice inspection of nuclear components or transport tanks. Users of the Code should refer to the pertinent codes, standards, laws, regulations, or other relevant documents for safety issues other than those relating to pressure integrity. Except for Sections XI and XII, and with a few other exceptions, the rules do not, of practical necessity, reflect the likelihood and consequences of deterioration in service related to specific service fluids or external operating environments. In formulating the rules, the Committee considers the needs of users, manufacturers, and inspectors of pressure vessels. The objective of the rules is to afford reasonably certain protection of life and property, and to provide a margin for deterioration in service to give a reasonably long, safe period of usefulness. Advancements in design and materials and evidence of experience have been recognized.

This Code contains mandatory requirements, specific prohibitions, and nonmandatory guidance for construction activities and inservice inspection and testing activities. The Code does not address all aspects of these activities and those aspects that are not specifically addressed should not be considered prohibited. The Code is not a handbook and cannot replace education, experience, and the use of engineering judgment. The phrase *engineering judgment* refers to technical judgments made by knowledgeable engineers experienced in the application of the Code. Engineering judgments must be consistent with Code philosophy, and such judgments must never be used to overrule mandatory requirements or specific prohibitions of the Code.

The Committee recognizes that tools and techniques used for design and analysis change as technology progresses and expects engineers to use good judgment in the application of these tools. The designer is responsible for complying with Code rules and demonstrating compliance with Code equations when such equations are mandatory. The Code neither requires nor prohibits the use of computers for the design or analysis of components constructed to the requirements of the Code. However, designers and engineers using computer programs for design or analysis are cautioned that they are responsible for all technical assumptions inherent in the programs they use and the application of these programs to their design.

* The information contained in this Foreword is not part of this American National Standard (ANS) and has not been processed in accordance with ANSI’s requirements for an ANS. Therefore, this Foreword may contain material that has not been subjected to public review or a consensus process. In addition, it does not contain requirements necessary for conformance to the Code.

** *Construction*, as used in this Foreword, is an all-inclusive term comprising materials, design, fabrication, examination, inspection, testing, certification, and overpressure protection.

The rules established by the Committee are not to be interpreted as approving, recommending, or endorsing any proprietary or specific design, or as limiting in any way the manufacturer's freedom to choose any method of design or any form of construction that conforms to the Code rules.

The Committee meets regularly to consider revisions of the rules, new rules as dictated by technological development, Code Cases, and requests for interpretations. Only the Committee has the authority to provide official interpretations of this Code. Requests for revisions, new rules, Code Cases, or interpretations shall be addressed to the Secretary in writing and shall give full particulars in order to receive consideration and action (see Submittal of Technical Inquiries to the Boiler and Pressure Vessel Standards Committees). Proposed revisions to the Code resulting from inquiries will be presented to the Committee for appropriate action. The action of the Committee becomes effective only after confirmation by ballot of the Committee and approval by ASME. Proposed revisions to the Code approved by the Committee are submitted to the American National Standards Institute (ANSI) and published at <http://go.asme.org/BPVCPublicReview> to invite comments from all interested persons. After public review and final approval by ASME, revisions are published at regular intervals in Editions of the Code.

The Committee does not rule on whether a component shall or shall not be constructed to the provisions of the Code. The scope of each Section has been established to identify the components and parameters considered by the Committee in formulating the Code rules.

Questions or issues regarding compliance of a specific component with the Code rules are to be directed to the ASME Certificate Holder (Manufacturer). Inquiries concerning the interpretation of the Code are to be directed to the Committee. ASME is to be notified should questions arise concerning improper use of the ASME Single Certification Mark.

When required by context in this Section, the singular shall be interpreted as the plural, and vice versa, and the feminine, masculine, or neuter gender shall be treated as such other gender as appropriate.

The words "shall," "should," and "may" are used in this Standard as follows:

- *Shall* is used to denote a requirement.
- *Should* is used to denote a recommendation.
- *May* is used to denote permission, neither a requirement nor a recommendation.

STATEMENT OF POLICY ON THE USE OF THE ASME SINGLE CERTIFICATION MARK AND CODE AUTHORIZATION IN ADVERTISING

ASME has established procedures to authorize qualified organizations to perform various activities in accordance with the requirements of the ASME Boiler and Pressure Vessel Code. It is the aim of the Society to provide recognition of organizations so authorized. An organization holding authorization to perform various activities in accordance with the requirements of the Code may state this capability in its advertising literature.

Organizations that are authorized to use the ASME Single Certification Mark for marking items or constructions that have been constructed and inspected in compliance with the ASME Boiler and Pressure Vessel Code are issued Certificates of Authorization. It is the aim of the Society to maintain the standing of the ASME Single Certification Mark for the benefit of the users, the enforcement jurisdictions, and the holders of the ASME Single Certification Mark who comply with all requirements.

Based on these objectives, the following policy has been established on the usage in advertising of facsimiles of the ASME Single Certification Mark, Certificates of Authorization, and reference to Code construction. The American Society of Mechanical Engineers does not “approve,” “certify,” “rate,” or “endorse” any item, construction, or activity and there shall be no statements or implications that might so indicate. An organization holding the ASME Single Certification Mark and/or a Certificate of Authorization may state in advertising literature that items, constructions, or activities “are built (produced or performed) or activities conducted in accordance with the requirements of the ASME Boiler and Pressure Vessel Code,” or “meet the requirements of the ASME Boiler and Pressure Vessel Code.” An ASME corporate logo shall not be used by any organization other than ASME.

The ASME Single Certification Mark shall be used only for stamping and nameplates as specifically provided in the Code. However, facsimiles may be used for the purpose of fostering the use of such construction. Such usage may be by an association or a society, or by a holder of the ASME Single Certification Mark who may also use the facsimile in advertising to show that clearly specified items will carry the ASME Single Certification Mark.

STATEMENT OF POLICY ON THE USE OF ASME MARKING TO IDENTIFY MANUFACTURED ITEMS

The ASME Boiler and Pressure Vessel Code provides rules for the construction of boilers, pressure vessels, and nuclear components. This includes requirements for materials, design, fabrication, examination, inspection, and stamping. Items constructed in accordance with all of the applicable rules of the Code are identified with the ASME Single Certification Mark described in the governing Section of the Code.

Markings such as “ASME,” “ASME Standard,” or any other marking including “ASME” or the ASME Single Certification Mark shall not be used on any item that is not constructed in accordance with all of the applicable requirements of the Code.

Items shall not be described on ASME Data Report Forms nor on similar forms referring to ASME that tend to imply that all Code requirements have been met when, in fact, they have not been. Data Report Forms covering items not fully complying with ASME requirements should not refer to ASME or they should clearly identify all exceptions to the ASME requirements.

SUBMITTAL OF TECHNICAL INQUIRIES TO THE BOILER AND PRESSURE VESSEL STANDARDS COMMITTEES (21)

1 INTRODUCTION

(a) The following information provides guidance to Code users for submitting technical inquiries to the applicable Boiler and Pressure Vessel (BPV) Standards Committee (hereinafter referred to as the Committee). See the guidelines on approval of new materials under the ASME Boiler and Pressure Vessel Code in Section II, Part D for requirements for requests that involve adding new materials to the Code. See the guidelines on approval of new welding and brazing materials in Section II, Part C for requirements for requests that involve adding new welding and brazing materials (“consumables”) to the Code.

Technical inquiries can include requests for revisions or additions to the Code requirements, requests for Code Cases, or requests for Code Interpretations, as described below:

(1) *Code Revisions*. Code revisions are considered to accommodate technological developments, to address administrative requirements, to incorporate Code Cases, or to clarify Code intent.

(2) *Code Cases*. Code Cases represent alternatives or additions to existing Code requirements. Code Cases are written as a Question and Reply, and are usually intended to be incorporated into the Code at a later date. When used, Code Cases prescribe mandatory requirements in the same sense as the text of the Code. However, users are cautioned that not all regulators, jurisdictions, or Owners automatically accept Code Cases. The most common applications for Code Cases are as follows:

(-a) to permit early implementation of an approved Code revision based on an urgent need

(-b) to permit use of a new material for Code construction

(-c) to gain experience with new materials or alternative requirements prior to incorporation directly into the Code

(3) *Code Interpretations*

(-a) Code Interpretations provide clarification of the meaning of existing requirements in the Code and are presented in Inquiry and Reply format. Interpretations do not introduce new requirements.

(-b) Interpretations will be issued only if existing Code text is ambiguous or conveys conflicting requirements. If a revision of the requirements is required to support the Interpretation, an Intent Interpretation will be issued in parallel with a revision to the Code.

(b) Code requirements, Code Cases, and Code Interpretations established by the Committee are not to be considered as approving, recommending, certifying, or endorsing any proprietary or specific design, or as limiting in any way the freedom of manufacturers, constructors, or Owners to choose any method of design or any form of construction that conforms to the Code requirements.

(c) Inquiries that do not comply with the following guidance or that do not provide sufficient information for the Committee’s full understanding may result in the request being returned to the Inquirer with no action.

2 INQUIRY FORMAT

Submittals to the Committee should include the following information:

(a) *Purpose*. Specify one of the following:

(1) request for revision of present Code requirements

(2) request for new or additional Code requirements

(3) request for Code Case

(4) request for Code Interpretation

(b) *Background*. The Inquirer should provide the information needed for the Committee’s understanding of the Inquiry, being sure to include reference to the applicable Code Section, Division, Edition, Addenda (if applicable), paragraphs, figures, and tables. This information should include a statement indicating why the included paragraphs, figures, or tables are ambiguous or convey conflicting requirements. Preferably, the Inquirer should provide a copy of, or relevant extracts from, the specific referenced portions of the Code.

(c) *Presentations.* The Inquirer may desire to attend or be asked to attend a meeting of the Committee to make a formal presentation or to answer questions from the Committee members with regard to the Inquiry. Attendance at a BPV Standards Committee meeting shall be at the expense of the Inquirer. The Inquirer's attendance or lack of attendance at a meeting will not be used by the Committee as a basis for acceptance or rejection of the Inquiry by the Committee. However, if the Inquirer's request is unclear, attendance by the Inquirer or a representative may be necessary for the Committee to understand the request sufficiently to be able to provide an Interpretation. If the Inquirer desires to make a presentation at a Committee meeting, the Inquirer should provide advance notice to the Committee Secretary, to ensure time will be allotted for the presentation in the meeting agenda. The Inquirer should consider the need for additional audiovisual equipment that might not otherwise be provided by the Committee. With sufficient advance notice to the Committee Secretary, such equipment may be made available.

3 CODE REVISIONS OR ADDITIONS

Requests for Code revisions or additions should include the following information:

(a) *Requested Revisions or Additions.* For requested revisions, the Inquirer should identify those requirements of the Code that they believe should be revised, and should submit a copy of, or relevant extracts from, the appropriate requirements as they appear in the Code, marked up with the requested revision. For requested additions to the Code, the Inquirer should provide the recommended wording and should clearly indicate where they believe the additions should be located in the Code requirements.

(b) *Statement of Need.* The Inquirer should provide a brief explanation of the need for the revision or addition.

(c) *Background Information.* The Inquirer should provide background information to support the revision or addition, including any data or changes in technology that form the basis for the request, that will allow the Committee to adequately evaluate the requested revision or addition. Sketches, tables, figures, and graphs should be submitted, as appropriate. The Inquirer should identify any pertinent portions of the Code that would be affected by the revision or addition and any portions of the Code that reference the requested revised or added paragraphs.

4 CODE CASES

Requests for Code Cases should be accompanied by a statement of need and background information similar to that described in 3(b) and 3(c), respectively, for Code revisions or additions. The urgency of the Code Case (e.g., project underway or imminent, new procedure) should be described. In addition, it is important that the request is in connection with equipment that will bear the ASME Single Certification Mark, with the exception of Section XI applications. The proposed Code Case should identify the Code Section and Division, and should be written as a Question and a Reply, in the same format as existing Code Cases. Requests for Code Cases should also indicate the applicable Code Editions and Addenda (if applicable) to which the requested Code Case applies.

5 CODE INTERPRETATIONS

(a) Requests for Code Interpretations should be accompanied by the following information:

(1) *Inquiry.* The Inquirer should propose a condensed and precise Inquiry, omitting superfluous background information and, when possible, composing the Inquiry in such a way that a "yes" or a "no" Reply, with brief limitations or conditions, if needed, can be provided by the Committee. The proposed question should be technically and editorially correct.

(2) *Reply.* The Inquirer should propose a Reply that clearly and concisely answers the proposed Inquiry question. Preferably, the Reply should be "yes" or "no," with brief limitations or conditions, if needed.

(3) *Background Information.* The Inquirer should include a statement indicating why the included paragraphs, figures, or tables are ambiguous or convey conflicting requirements. The Inquirer should provide any need or background information, such as described in 3(b) and 3(c), respectively, for Code revisions or additions, that will assist the Committee in understanding the proposed Inquiry and Reply.

If the Inquirer believes a revision of the Code requirements would be helpful to support the Interpretation, the Inquirer may propose such a revision for consideration by the Committee. In most cases, such a proposal is not necessary.

(b) Requests for Code Interpretations should be limited to an Interpretation of a particular requirement in the Code or in a Code Case. Except with regard to interpreting a specific Code requirement, the Committee is not permitted to consider consulting-type requests such as the following:

(1) a review of calculations, design drawings, welding qualifications, or descriptions of equipment or parts to determine compliance with Code requirements

(2) a request for assistance in performing any Code-prescribed functions relating to, but not limited to, material selection, designs, calculations, fabrication, inspection, pressure testing, or installation

(3) a request seeking the rationale for Code requirements

6 SUBMITTALS

(a) *Submittal.* Requests for Code Interpretation should preferably be submitted through the online Interpretation Submittal Form. The form is accessible at <http://go.asme.org/InterpretationRequest>. Upon submittal of the form, the Inquirer will receive an automatic e-mail confirming receipt. If the Inquirer is unable to use the online form, the Inquirer may mail the request to the following address:

Secretary
ASME Boiler and Pressure Vessel Committee
Two Park Avenue
New York, NY 10016-5990

All other Inquiries should be mailed to the Secretary of the BPV Committee at the address above. Inquiries are unlikely to receive a response if they are not written in clear, legible English. They must also include the name of the Inquirer and the company they represent or are employed by, if applicable, and the Inquirer's address, telephone number, fax number, and e-mail address, if available.

(b) *Response.* The Secretary of the appropriate Committee will provide a written response, via letter or e-mail, as appropriate, to the Inquirer, upon completion of the requested action by the Committee. Inquirers may track the status of their Interpretation Request at <http://go.asme.org/Interpretations>.

PERSONNEL

(21)

ASME Boiler and Pressure Vessel Standards Committees, Subgroups, and Working Groups

January 1, 2021

TECHNICAL OVERSIGHT MANAGEMENT COMMITTEE (TOMC)

R. E. McLaughlin, <i>Chair</i>	J. F. Henry
N. A. Finney, <i>Vice Chair</i>	R. B. Keating
S. J. Rossi, <i>Staff Secretary</i>	B. Linnemann
G. Aurioles, Sr.	W. M. Lundy
R. W. Barnes	D. I. Morris
T. L. Bedeaux	T. P. Pastor
D. A. Bowers	M. D. Rana
C. Brown	S. C. Roberts
D. B. DeMichael	F. J. Schaaf, Jr.
R. P. Deubler	G. Scribner
P. D. Edwards	W. J. Sperko
J. G. Feldstein	D. Srnic
G. W. Galanes	R. W. Swayne
J. A. Hall	M. Wadkinson
T. E. Hansen	J. E. Batey, <i>Contributing Member</i>
G. W. Hembree	

Subgroup on Research and Development (TOMC)

S. C. Roberts, <i>Chair</i>	B. Hrubala
S. J. Rossi, <i>Staff Secretary</i>	R. B. Keating
R. W. Barnes	R. E. McLaughlin
N. A. Finney	T. P. Pastor
J. F. Henry	D. Andrei, <i>Contributing Member</i>
W. Hoffelner	

Subgroup on Strategic Initiatives (TOMC)

N. A. Finney, <i>Chair</i>	M. H. Jawad
S. J. Rossi, <i>Staff Secretary</i>	R. B. Keating
R. W. Barnes	R. E. McLaughlin
T. L. Bedeaux	T. P. Pastor
G. W. Hembree	S. C. Roberts
J. F. Henry	

Task Group on Remote Inspection and Examination (SI-TOMC)

S. C. Roberts, <i>Chair</i>	M. Tannenbaum
P. J. Coco	J. Cameron, <i>Alternate</i>
N. A. Finney	P. Lang, <i>Contributing Member</i>
S. A. Marks	J. Pang, <i>Contributing Member</i>
R. Rockwood	S. J. Rossi, <i>Contributing Member</i>
C. Stevens	C. A. Sanna, <i>Contributing Member</i>

Special Working Group on High Temperature Technology (TOMC)

D. Dewees, <i>Chair</i>	B. F. Hantz
F. W. Brust	J. F. Henry
T. D. Burchell	R. I. Jetter
P. R. Donavin	P. Smith

ADMINISTRATIVE COMMITTEE

R. E. McLaughlin, <i>Chair</i>	R. B. Keating
N. A. Finney, <i>Vice Chair</i>	B. Linnemann
S. J. Rossi, <i>Staff Secretary</i>	M. D. Rana
D. A. Bowers	S. C. Roberts
J. Cameron	R. R. Stevenson
D. B. DeMichael	R. W. Swayne
J. A. Hall	

MARINE CONFERENCE GROUP

E. Lawson, <i>Staff Secretary</i>	H. N. Patel
J. G. Hungerbuhler, Jr.	N. Prokopuk
G. Nair	J. D. Reynolds

CONFERENCE COMMITTEE

C. B. Cantrell — Nebraska, <i>Chair</i>	A. M. Lorimor — South Dakota
J. T. Amato — Ohio, <i>Secretary</i>	M. Mailman — Northwest Territories, Canada
W. Anderson — Mississippi	W. McGivney — City of New York, New York
P. Bearden — Minnesota	S. F. Noonan — Maryland
R. Becker — Colorado	A. K. Oda — Washington
T. D. Boggs — Missouri	B. S. Oliver — New Hampshire
R. A. Boillard — Indiana	J. L. Oliver — Nevada
R. J. Bunte — Iowa	M. Poehlmann — Alberta, Canada
J. H. Burpee — Maine	P. B. Polick — Illinois
S. Chapman — Tennessee	J. F. Porcella — West Virginia
T. G. Clark — Oregon	C. F. Reyes — California
B. J. Crawford — Georgia	W. J. Ross — Pennsylvania
E. L. Creaser — New Brunswick, Canada	M. J. Ryan — City of Chicago, Illinois
J. J. Dacanay — Hawaii	M. H. Sansone — New York
R. DeLury — Manitoba, Canada	T. S. Seime — North Dakota
C. Dinic — Ontario, Canada	C. S. Selinger — Saskatchewan, Canada
D. Eastman — Newfoundland and Labrador, Canada	J. E. Sharier — Ohio
D. A. Ehler — Nova Scotia, Canada	R. Spiker — North Carolina
S. D. Frazier — Washington	D. J. Stenrose — Michigan
T. J. Granneman II — Oklahoma	R. J. Stimson II — Kansas
S. Harder — Arizona	R. K. Sturm — Utah
E. G. Hilton — Virginia	D. K. Sullivan — Arkansas
M. L. Jordan — Kentucky	J. Taveras — Rhode Island
R. Kamboj — British Columbia, Canada	G. Teel — California
E. Kawa, Jr. — Massachusetts	S. R. Townsend — Prince Edward Island, Canada
A. Khssassi — Quebec, Canada	R. D. Trout — Texas
D. Kinney — North Carolina	D. M. Warburton — Florida
J. Klug — City of Milwaukee, Wisconsin	M. Washington — New Jersey
K. S. Lane — Alaska	E. Wiggins — Alabama
J. LeSage, Jr. — Louisiana	

INTERNATIONAL INTEREST REVIEW GROUP

V. Felix
Y.-G. Kim
S. H. Leong
W. Lin
O. F. Manafa

C. Minu
Y.-W. Park
A. R. Reynaga Nogales
P. Williamson

COMMITTEE ON POWER BOILERS (BPV I)

R. E. McLaughlin, *Chair*
E. M. Ortman, *Vice Chair*
U. D'Urso, *Staff Secretary*
D. I. Anderson
J. L. Arnold
K. K. Coleman
P. D. Edwards
J. G. Feldstein
S. Fincher
G. W. Galanes
T. E. Hansen
J. F. Henry
J. S. Hunter
M. Ishikawa
G. B. Komora
F. Massi
L. Moedinger
P. A. Molvie
Y. Oishi

D. E. Tompkins
D. E. Tuttle
J. Vattappilly
M. Wadkinson
R. V. Wielgoszinski
F. Zeller
H. Michael, *Delegate*
D. L. Berger, *Honorary Member*
D. N. French, *Honorary Member*
J. Hainsworth, *Honorary Member*
W. L. Lowry, *Honorary Member*
J. R. MacKay, *Honorary Member*
T. C. McGough, *Honorary Member*
J. T. Pillow, *Honorary Member*
B. W. Roberts, *Honorary Member*
R. D. Schueler, Jr., *Honorary Member*
J. M. Tanzosh, *Honorary Member*
R. L. Williams, *Honorary Member*
L. W. Yoder, *Honorary Member*

Executive Committee (BPV I)

E. M. Ortman, *Chair*
R. E. McLaughlin, *Vice Chair*
D. I. Anderson
J. L. Arnold
J. R. Braun
K. K. Coleman
H. Dalal

T. Dhanraj
U. D'Urso
P. F. Gilston
K. Hayes
P. Jennings
A. Spangenberg
D. E. Tompkins

Subgroup on Design (BPV I)

D. I. Anderson, *Chair*
L. S. Tsai, *Secretary*
P. Becker
D. Dewees
G. B. Komora
L. Krupp

P. A. Molvie
N. Ranck
J. Vattappilly
M. Wadkinson
J. P. Glaspie, *Contributing Member*

Subgroup on Fabrication and Examination (BPV I)

J. L. Arnold, *Chair*
P. F. Gilston, *Vice Chair*
P. Becker, *Secretary*
A. Biesecker
K. K. Coleman
S. Fincher
G. W. Galanes
T. E. Hansen

P. Jennings
M. Lewis
C. T. McDaris
R. E. McLaughlin
R. J. Newell
Y. Oishi
R. V. Wielgoszinski

Subgroup on General Requirements and Piping (BPV I)

E. M. Ortman, *Chair*
D. E. Tompkins, *Vice Chair*
F. Massi, *Secretary*
P. D. Edwards
T. E. Hansen
M. Ishikawa
M. Lemmons
R. E. McLaughlin

L. Moedinger
B. J. Mollitor
Y. Oishi
D. E. Tuttle
M. Wadkinson
R. V. Wielgoszinski
W. L. Lowry, *Contributing Member*

Subgroup on Locomotive Boilers (BPV I)

J. R. Braun, *Chair*
S. M. Butler, *Secretary*
A. Biesecker
C. Cross
G. W. Galanes
D. W. Griner

M. A. Janssen
S. A. Lee
L. Moedinger
G. M. Ray
M. W. Westland

Subgroup on Materials (BPV I)

K. K. Coleman, *Chair*
K. Hayes, *Vice Chair*
M. Lewis, *Secretary*
S. H. Bowes
G. W. Galanes
P. F. Gilston
J. F. Henry
J. S. Hunter

E. Liebl
F. Masuyama
M. Ortolani
D. W. Raho
J. Vattappilly
F. Zeller
B. W. Roberts, *Contributing Member*
J. M. Tanzosh, *Contributing Member*

Subgroup on Solar Boilers (BPV I)

P. Jennings, *Chair*
R. E. Hearne, *Secretary*
S. Fincher

J. S. Hunter
F. Massi
P. Swarnkar

Task Group on Modernization (BPV I)

D. I. Anderson, *Chair*
U. D'Urso, *Staff Secretary*
J. L. Arnold
D. Dewees
G. W. Galanes
J. P. Glaspie
T. E. Hansen

J. F. Henry
R. E. McLaughlin
P. A. Molvie
E. M. Ortman
D. E. Tuttle
J. Vattappilly

Germany International Working Group (BPV I)

A. Spangenberg, *Chair*
P. Chavdarov, *Secretary*
B. Daume
J. Fleischfresser
R. Kauer
D. Koelbl
S. Krebs
T. Ludwig
R. A. Meyers
H. Michael

F. Miunske
M. Sykora
R. Helmholdt, *Contributing Member*
J. Henrichsmeyer, *Contributing Member*
B. Müller, *Contributing Member*
P. Paluszkiwicz, *Contributing Member*
R. Uebel, *Contributing Member*

India International Working Group (BPV I)

H. Dalal, *Chair*
 T. Dhanraj, *Vice Chair*
 K. Thanupillai, *Secretary*
 P. Brahma
 S. Chakrabarti
 A. Hantodkar
 S. A. Kumar
 A. J. Patil
 A. R. Patil

S. Purkait
 M. G. Rao
 U. Revisankaran
 G. U. Shanker
 D. K. Shrivastava
 K. Singha
 R. Sundararaj
 S. Venkataramana

Subgroup on Ferrous Specifications (BPV II)

A. Appleton, *Chair*
 K. M. Hottle, *Vice Chair*
 C. Hyde, *Secretary*
 B. M. Dingman
 M. J. Dosdourian
 O. Elkadim
 D. Fialkowski
 J. F. Grubb

J. Gundlach
 D. S. Janikowski
 S. G. Lee
 W. C. Mack
 K. E. Orié
 D. Poweleit
 E. Upitis
 J. D. Fritz, *Contributing Member*

COMMITTEE ON MATERIALS (BPV II)

J. Cameron, *Chair*
 J. F. Grubb, *Vice Chair*
 C. E. O'Brien, *Staff Secretary*
 A. Appleton
 P. Chavdarov
 J. R. Foulds
 D. W. Gandy
 J. A. Hall
 J. F. Henry
 K. M. Hottle
 M. Ishikawa
 K. Kimura
 F. Masuyama
 K. E. Orié
 D. W. Rahoi
 W. Ren
 E. Shapiro
 R. C. Sutherland
 F. Zeller
 O. Oldani, *Delegate*
 F. Abe, *Contributing Member*

A. Chaudouet, *Contributing Member*
 D. B. Denis, *Contributing Member*
 J. D. Fritz, *Contributing Member*
 W. Hoffelner, *Contributing Member*
 M. Katcher, *Contributing Member*
 R. K. Nanstad, *Contributing Member*
 M. L. Nayyar, *Contributing Member*
 D. T. Peters, *Contributing Member*
 B. W. Roberts, *Contributing Member*
 J. J. Sanchez-Hanton, *Contributing Member*
 R. W. Swindeman, *Contributing Member*
 J. M. Tanzosh, *Contributing Member*
 E. Upitis, *Contributing Member*
 R. G. Young, *Contributing Member*
 T. M. Cullen, *Honorary Member*
 W. D. Edsall, *Honorary Member*
 G. C. Hsu, *Honorary Member*
 C. E. Spaeder, Jr., *Honorary Member*
 A. W. Zeuthen, *Honorary Member*

Subgroup on International Material Specifications (BPV II)

M. Ishikawa, *Chair*
 A. R. Nywening, *Vice Chair*
 B. Mruk, *Secretary*
 A. Chaudouet
 P. Chavdarov
 H. Chen
 A. F. Garbolevsky
 D. O. Henry

W. M. Lundy
 F. Zeller
 C. Zhou
 O. Oldani, *Delegate*
 H. Lorenz, *Contributing Member*
 T. F. Miskell, *Contributing Member*
 E. Upitis, *Contributing Member*

Subgroup on Nonferrous Alloys (BPV II)

E. Shapiro, *Chair*
 S. Yem, *Vice Chair*
 J. Robertson, *Secretary*
 R. M. Beldyk
 J. M. Downs
 J. F. Grubb
 W. MacDonald
 D. Maitra
 J. A. McMaster

D. W. Rahoi
 W. Ren
 R. C. Sutherland
 J. Weritz
 A. Williams
 R. Wright
 D. B. Denis, *Contributing Member*
 M. Katcher, *Contributing Member*
 D. T. Peters, *Contributing Member*

Executive Committee (BPV II)

J. Cameron, *Chair*
 C. E. O'Brien, *Staff Secretary*
 A. Appleton
 G. W. Galanes
 J. F. Grubb
 J. F. Henry

M. Ishikawa
 D. L. Kurle
 R. W. Mikitka
 E. Shapiro
 R. C. Sutherland

Subgroup on Physical Properties (BPV II)

J. F. Grubb, *Chair*
 P. K. Rai, *Vice Chair*
 G. Aurióles, Sr.
 D. Chandiramani
 P. Chavdarov
 H. Eshraghi
 B. F. Hantz
 R. D. Jones

P. K. Lam
 S. Neilsen
 D. W. Rahoi
 E. Shapiro
 D. K. Verma
 S. Yem
 D. B. Denis, *Contributing Member*

Subgroup on External Pressure (BPV II)

D. L. Kurle, *Chair*
 S. Guzey, *Vice Chair*
 J. A. A. Morrow, *Secretary*
 E. Alexis
 L. F. Campbell
 H. Chen
 D. S. Griffin

J. F. Grubb
 M. H. Jawad
 S. Krishnamurthy
 R. W. Mikitka
 P. K. Rai
 M. Wadkinson
 M. Katcher, *Contributing Member*

Subgroup on Strength, Ferrous Alloys (BPV II)

S. W. Knowles, *Vice Chair*
 L. S. Nicol, *Secretary*
 J. R. Foulds
 G. W. Galanes
 J. A. Hall
 J. F. Henry
 M. Ishikawa
 F. Masuyama
 M. Ortolani

M. Osterfoss
 D. W. Rahoi
 S. Rosinski
 M. Ueyama
 F. Zeller
 F. Abe, *Contributing Member*
 A. Di Rienzo, *Contributing Member*
 M. Nair, *Contributing Member*
 R. G. Young, *Contributing Member*

Subgroup on Strength of Weldments (BPV II & BPV IX)

G. W. Galanes, <i>Chair</i>	J. Penso
K. L. Hayes, <i>Vice Chair</i>	D. W. Rahoi
S. H. Bowes, <i>Secretary</i>	B. W. Roberts
K. K. Coleman	W. J. Sperko
M. Denault	J. P. Swezy, Jr.
J. R. Foulds	M. Ueyama
D. W. Gandy	P. D. Fenner, <i>Contributing Member</i>
M. Ghahremani	J. J. Sanchez-Hanton, <i>Contributing Member</i>
J. F. Henry	
W. F. Newell, Jr.	

Working Group on Materials Database (BPV II)

W. Hoffelner, <i>Vice Chair</i>	J. L. Arnold, <i>Contributing Member</i>
C. E. O'Brien, <i>Staff Secretary</i>	D. T. Peters, <i>Contributing Member</i>
F. Abe	W. Ren, <i>Contributing Member</i>
J. R. Foulds	B. W. Roberts, <i>Contributing Member</i>
J. F. Henry	R. W. Swindeman, <i>Contributing Member</i>
R. C. Sutherland	
D. Andrei, <i>Contributing Member</i>	

Working Group on Creep Strength Enhanced Ferritic Steels (BPV II)

M. Ortolani, <i>Chair</i>	J. J. Sanchez-Hanton
G. W. Galanes, <i>Vice Chair</i>	J. A. Siefert
S. H. Bowes	W. J. Sperko
K. K. Coleman	F. Zeller
J. R. Foulds	F. Abe, <i>Contributing Member</i>
J. F. Henry	G. Cumino, <i>Contributing Member</i>
M. Lang	P. D. Fenner, <i>Contributing Member</i>
S. Luke	R. W. Swindeman, <i>Contributing Member</i>
F. Masuyama	
T. Melfi	J. M. Tanzosh, <i>Contributing Member</i>
W. F. Newell, Jr.	

Working Group on Data Analysis (BPV II)

J. F. Grubb, <i>Chair</i>	F. Abe, <i>Contributing Member</i>
J. R. Foulds, <i>Vice Chair</i>	W. Hoffelner, <i>Contributing Member</i>
J. F. Henry	M. Katcher, <i>Contributing Member</i>
F. Masuyama	D. T. Peters, <i>Contributing Member</i>
M. Ortolani	B. W. Roberts, <i>Contributing Member</i>
W. Ren	R. W. Swindeman, <i>Contributing Member</i>
M. Subanovic	
M. J. Swindeman	

China International Working Group (BPV II)

S. Liu, <i>Chair</i>	Q.-J. Wang
Yong Zhang, <i>Vice Chair</i>	X. Wang
A. T. Xu, <i>Secretary</i>	F. Yang
W. Fang	G. Yang
Q. C. Feng	H.-C. Yang
S. Huo	J. Yang
F. Kong	R. Ye
H. Li	L. Yin
J. Li	H. Zhang
S. Li	X.-H. Zhang
Z. Rongcan	Yingkai Zhang
S. Tan	Q. Zhao
C. Wang	S. Zhao
J. Wang	

COMMITTEE ON CONSTRUCTION OF NUCLEAR FACILITY COMPONENTS (BPV III)

R. B. Keating, <i>Chair</i>	M. A. Lockwood
T. M. Adams, <i>Vice Chair</i>	K. A. Manoly
D. E. Matthews, <i>Vice Chair</i>	K. Matsunaga
K. Verderber, <i>Staff Secretary</i>	B. McGlone
A. Appleton	S. McKillop
S. Asada	J. C. Minichiello
R. W. Barnes	M. N. Mitchell
W. H. Borter	T. Nagata
M. E. Cohen	J. B. Ossmann
R. P. Deubler	S. Pellet
P. R. Donavin	E. L. Pleins
A. C. Eberhardt	S. Sham
J. V. Gardiner	W. J. Sperko
J. Grimm	C. T. Smith, <i>Contributing Member</i>
S. Hunter	W. K. Sowder, Jr., <i>Contributing Member</i>
R. M. Jessee	M. Zhou, <i>Contributing Member</i>
R. I. Jetter	D. K. Morton, <i>Honorary Member</i>
C. C. Kim	R. F. Reedy, Sr., <i>Honorary Member</i>
G. H. Koo	
V. Kostarev	

Executive Committee (BPV III)

R. B. Keating, <i>Chair</i>	D. E. Matthews
K. Verderber, <i>Staff Secretary</i>	S. McKillop
T. M. Adams	J. A. Munshi
P. R. Donavin	S. Sham
J. V. Gardiner	W. K. Sowder, Jr.
J. Grimm	

Subcommittee on Design (BPV III)

P. R. Donavin, <i>Chair</i>	M. N. Mitchell
R. P. Deubler	S. Sham
M. A. Gray	W. F. Weitze
R. I. Jetter	G. L. Hollinger, <i>Contributing Member</i>
R. B. Keating	M. H. Jawad, <i>Contributing Member</i>
K. A. Manoly	W. J. O'Donnell, Sr., <i>Contributing Member</i>
D. E. Matthews	K. Wright, <i>Contributing Member</i>
S. McKillop	

Subgroup on Component Design (SC-D) (BPV III)

D. E. Matthews, <i>Chair</i>	K. A. Manoly
P. Vock, <i>Vice Chair</i>	R. J. Masterson
S. Pellet, <i>Secretary</i>	J. C. Minichiello
T. M. Adams	T. Mitsuhashi
D. J. Ammerman	D. Murphy
G. A. Antaki	T. M. Musto
S. Asada	T. Nagata
J. F. Ball	J. R. Stinson
C. Basavaraju	G. Z. Tokarski
D. Chowdhury	J. P. Tucker
R. P. Deubler	S. Willoughby-Braun
P. Hirschberg	C. Wilson
M. Kassir	A. A. Dermenjian, <i>Contributing Member</i>
R. B. Keating	I. Saito, <i>Contributing Member</i>
D. Keck	K. R. Wichman, <i>Honorary Member</i>
O.-S. Kim	
T. R. Liszkai	

Working Group on Core Support Structures (SG-CD) (BPV III)

D. Keck, <i>Chair</i>	M. D. Snyder
R. Z. Ziegler, <i>Vice Chair</i>	R. Vollmer
R. Martin, <i>Secretary</i>	T. M. Wiger
G. W. Delport	C. Wilson
L. C. Hartless	Y. Wong
T. R. Liszkai	A. Tsirigotis, <i>Alternate</i>
H. S. Mehta	J. F. Kielb, <i>Contributing Member</i>
M. Nakajima	

Working Group on Design of Division 3 Containment Systems (SG-CD) (BPV III)

D. J. Ammerman, <i>Chair</i>	D. Siromani
S. Klein, <i>Secretary</i>	X. Zhai
V. Broz	X. Zhang
D. W. Lewis	J. C. Minichiello, <i>Contributing Member</i>
A. Rigato	

Working Group on HDPE Design of Components (SG-CD) (BPV III)

T. M. Musto, <i>Chair</i>	D. P. Munson
J. B. Ossmann, <i>Secretary</i>	F. J. Schaaf, Jr.
M. Brandes	R. Stakenborghs
S. Choi	J. Wright
J. R. Hebeisen	M. T. Audrain, <i>Alternate</i>
P. Krishnaswamy	D. Burwell, <i>Contributing Member</i>
M. Kuntz	J. C. Minichiello, <i>Contributing Member</i>
K. A. Manoly	
M. Martin	

Working Group on Piping (SG-CD) (BPV III)

G. A. Antaki, <i>Chair</i>	J. F. McCabe
G. Z. Tokarski, <i>Secretary</i>	I.-K. Nam
C. Basavaraju	J. O'Callaghan
J. Catalano	K. E. Reid II
F. Claeys	N. C. Sutherland
C. M. Faidy	D. Vlaicu
R. Farrell	S. Weindorf
R. G. Gilada	C.-I. Wu
N. M. Graham	T. M. Adams, <i>Contributing Member</i>
M. A. Gray	R. J. Gurdal, <i>Contributing Member</i>
R. W. Haupt	R. B. Keating, <i>Contributing Member</i>
A. Hirano	Y. Liu, <i>Contributing Member</i>
P. Hirschberg	J. C. Minichiello, <i>Contributing Member</i>
M. Kassar	
J. Kawahata	A. N. Nguyen, <i>Contributing Member</i>
V. Kostarev	M. S. Sills, <i>Contributing Member</i>
D. Lieb	E. A. Wais, <i>Contributing Member</i>
T. B. Littleton	

Working Group on Pressure Relief (SG-CD) (BPV III)

J. F. Ball, <i>Chair</i>	I. H. Tseng
K. R. May, <i>Vice Chair</i>	J. Yu
R. Krithivasan, <i>Secretary</i>	N. J. Hansing, <i>Alternate</i>
J. W. Dickson	J. M. Levy, <i>Alternate</i>
S. Jones	B. J. Yonsky, <i>Alternate</i>
R. Lack	S. T. French, <i>Contributing Member</i>
D. Miller	D. B. Ross, <i>Contributing Member</i>
T. Patel	S. Ruesenberg, <i>Contributing Member</i>
K. Shores	

Working Group on Pumps (SG-CD) (BPV III)

D. Chowdhury, <i>Chair</i>	J. Sulley
J. V. Gregg, Jr., <i>Secretary</i>	A. G. Washburn
M. D. Eftychiou	Y. Wong
R. A. Fleming	I. H. Tseng, <i>Alternate</i>
S. Hughes	X. Di, <i>Contributing Member</i>
J. Kikushima	C. Gabhart, <i>Contributing Member</i>
K. J. Noel	R. Ladefian, <i>Contributing Member</i>

Working Group on Supports (SG-CD) (BPV III)

J. R. Stinson, <i>Chair</i>	S. Pellet
U. S. Bandyopadhyay, <i>Secretary</i>	G. Z. Tokarski
K. Avrithi	A. Tsirigotis
F. J. Birch	L. Vandersip
N. M. Bisceglia	P. Wiseman
R. P. Deubler	J. Huang, <i>Alternate</i>
N. M. Graham	R. J. Masterson, <i>Contributing Member</i>
Y. Matsubara	

Working Group on Valves (SG-CD) (BPV III)

P. Vock, <i>Chair</i>	C. A. Mizer
S. Jones, <i>Secretary</i>	H. O'Brien
M. C. Buckley	J. O'Callaghan
A. Cardillo	K. E. Reid II
R. Farrell	J. Sulley
G. A. Jolly	I. H. Tseng
J. Lambin	J. P. Tucker
T. Lippucci	N. J. Hansing, <i>Alternate</i>

Working Group on Vessels (SG-CD) (BPV III)

D. Murphy, <i>Chair</i>	M. C. Scott
S. Willoughby-Braun, <i>Secretary</i>	P. K. Shah
J. Arthur	C. Turylo
C. Basavaraju	D. Vlaicu
D. Keck	C. Wilson
J. I. Kim	T. Yamazaki
O.-S. Kim	R. Z. Ziegler
D. E. Matthews	B. Basu, <i>Contributing Member</i>
T. Mitsuhashi	R. B. Keating, <i>Contributing Member</i>
T. J. Schriefer	W. F. Weitze, <i>Contributing Member</i>

Subgroup on Design Methods (SC-D) (BPV III)

S. McKillop, <i>Chair</i>	J. I. Kim
P. R. Donavin, <i>Vice Chair</i>	W. J. O'Donnell, Sr.
J. Wen, <i>Secretary</i>	W. D. Reinhardt
K. Avrithi	P. Smith
L. Davies	S. D. Snow
R. Farrell	R. Vollmer
S. R. Gosselin	W. F. Weitze
M. A. Gray	T. M. Adams, <i>Contributing Member</i>
J. V. Gregg, Jr.	C. W. Bruny, <i>Contributing Member</i>
K. Hsu	H. T. Harrison III, <i>Contributing Member</i>
R. Kalnas	
D. Keck	K. Wright, <i>Contributing Member</i>

Working Group on Design Methodology (SG-DM) (BPV III)

R. Farrell, <i>Chair</i>	W. F. Weitze
R. Vollmer, <i>Secretary</i>	J. Wen
K. Avrithi	T. M. Wiger
C. Basavaraju	G. Banyay, <i>Contributing Member</i>
C. M. Faidy	D. S. S. Bartran, <i>Contributing Member</i>
C. F. Heberling II	
M. Kassir	R. D. Blevins, <i>Contributing Member</i>
J. I. Kim	M. R. Breach, <i>Contributing Member</i>
T. R. Liszkai	C. W. Bruny, <i>Contributing Member</i>
K. Matsunaga	D. L. Caldwell, <i>Contributing Member</i>
S. McKillop	H. T. Harrison III, <i>Contributing Member</i>
B. Pellereau	
S. Ranganath	P. Hirschberg, <i>Contributing Member</i>
W. D. Reinhardt	R. B. Keating, <i>Contributing Member</i>
P. K. Shah	A. Walker, <i>Contributing Member</i>
S. D. Snow	K. Wright, <i>Contributing Member</i>
S. Wang	

Working Group on Environmental Fatigue Evaluation Methods (SG-DM) (BPV III)

M. A. Gray, <i>Chair</i>	P. Hirschberg
W. F. Weitze, <i>Secretary</i>	H. S. Mehta
S. Asada	J.-S. Park
K. Avrithi	B. Pellereau
R. C. Cipolla	G. L. Stevens
T. M. Damiani	D. Vlaicu
C. M. Faidy	K. Wang
T. D. Gilman	R. Z. Ziegler
S. R. Gosselin	S. Cuvilliez, <i>Contributing Member</i>
Y. He	K. Wright, <i>Contributing Member</i>
A. Hirano	

Working Group on Fatigue Strength (SG-DM) (BPV III)

P. R. Donavin, <i>Chair</i>	S. H. Kleinsmith
M. S. Shelton, <i>Secretary</i>	H. S. Mehta
T. M. Damiani	B. Pellereau
D. W. DeJohn	S. Ranganath
C. M. Faidy	G. L. Stevens
P. Gill	Y. Wang
S. R. Gosselin	W. F. Weitze
R. J. Gurdal	Y. Zou
C. F. Heberling II	D. Dewees, <i>Contributing Member</i>
C. E. Hinnant	S. Majumdar, <i>Contributing Member</i>
P. Hirschberg	W. J. O'Donnell, Sr., <i>Contributing Member</i>
K. Hsu	
J. I. Kim	K. Wright, <i>Contributing Member</i>

Working Group on Probabilistic Methods in Design (SG-DM) (BPV III)

M. Golliet, <i>Chair</i>	D. O. Henry
R. Kalnas, <i>Vice Chair</i>	A. Hirano
T. Asayama	A. Martin
K. Avrithi	P. J. O'Regan
G. Brouette	B. Pellereau
J. Hakii	R. S. Hill III, <i>Contributing Member</i>

Special Working Group on Computational Modeling for Explicit Dynamics (SG-DM) (BPV III)

D. J. Ammerman, <i>Vice Chair</i>	P. Y.-K. Shih
V. Broz, <i>Secretary</i>	S. D. Snow
J. M. Jordan	C.-F. Tso
S. Kuehner	M. C. Yaksh
D. Molitoris	U. Zencker
W. D. Reinhardt	

Working Group on Allowable Stress Criteria (SG-HTR) (BPV III)

R. Wright, <i>Chair</i>	R. Rupp
M. McMurtrey, <i>Secretary</i>	S. Sham
K. Kimura	Y. Wang
D. Maitra	X. Wei
R. J. McReynolds	J. R. Foulds, <i>Contributing Member</i>
M. C. Messner	R. W. Swindeman, <i>Contributing Member</i>
W. Ren	

Working Group on Analysis Methods (SG-HTR) (BPV III)

M. C. Messner, <i>Chair</i>	S. Sham
R. W. Barnes	X. Wei
J. A. Blanco	S. X. Xu
P. Carter	T. Hassan, <i>Contributing Member</i>
M. E. Cohen	S. Krishnamurthy, <i>Contributing Member</i>
R. I. Jetter	
G. H. Koo	M. J. Swindeman, <i>Contributing Member</i>
H. Qian	

Working Group on Creep-Fatigue and Negligible Creep (SG-HTR) (BPV III)

S. Sham, <i>Chair</i>	G. H. Koo
Y. Wang, <i>Secretary</i>	M. McMurtrey
M. Ando	M. C. Messner
F. W. Brust	J. C. Poehler
P. Carter	H. Qian
M. E. Cohen	X. Wei
R. I. Jetter	

Working Group on High Temperature Flaw Evaluation (SG-HTR) (BPV III)

F. W. Brust, <i>Chair</i>	H. Qian
P. Carter	P. J. Rush
S. Kalyanam	C. J. Sallaberry
B.-L. Lyow	D. J. Shim
M. C. Messner	X. Wei
J. C. Poehler	S. X. Xu

Subgroup on General Requirements (BPV III)

J. V. Gardiner, <i>Chair</i>	E. C. Renaud
N. DeSantis, <i>Secretary</i>	T. N. Rezk
V. Apostolescu	J. Rogers
A. Appleton	D. J. Roszman
S. Bell	R. Spuhl
J. R. Berry	G. E. Szabatura
G. Brouette	D. M. Vickery
G. C. Deleanu	J. DeKleine, <i>Contributing Member</i>
J. W. Highlands	H. Michael, <i>Contributing Member</i>
E. V. Imbro	C. T. Smith, <i>Contributing Member</i>
K. A. Kavanagh	W. K. Sowder, Jr., <i>Contributing Member</i>
Y.-S. Kim	
B. McGlone	

Working Group on General Requirements (SG-GR) (BPV III)

B. McGlone, <i>Chair</i>	K. A. Kavanagh
J. Grimm, <i>Secretary</i>	Y.-S. Kim
V. Apostolescu	D. T. Meisch
A. Appleton	R. B. Patel
S. Bell	E. C. Renaud
J. R. Berry	T. N. Rezk
G. Brouette	J. Rogers
J. Carter	D. J. Roszman
P. J. Coco	B. S. Sandhu
N. DeSantis	R. Spuhl
Y. Diaz-Castillo	J. F. Strunk
O. Elkadim	G. E. Szabatura
J. V. Gardiner	D. M. Vickery
S. M. Goodwin	J. L. Williams
J. Harris	J. DeKleine, <i>Contributing Member</i>
J. W. Highlands	S. F. Harrison, Jr., <i>Contributing Member</i>
E. V. Imbro	

Special Working Group on General Requirements Consolidation (SG-GR) (BPV III)

J. V. Gardiner, <i>Chair</i>	R. B. Patel
J. Grimm, <i>Vice Chair</i>	E. C. Renaud
C. T. Smith, <i>Vice Chair</i>	R. Spuhl
Y. Diaz-Castillo	J. L. Williams

Working Group on General Requirements for Graphite and Ceramic Composite Core Components and Assemblies (SG-GR) (BPV III)

A. Appleton, <i>Chair</i>	M. N. Mitchell
W. J. Geringer, <i>Secretary</i>	E. C. Renaud
J. R. Berry	W. Windes
Y. Diaz-Castillo	

Subgroup on Materials, Fabrication, and Examination (BPV III)

J. Grimm, <i>Chair</i>	M. Lashley
S. Hunter, <i>Secretary</i>	D. W. Mann
W. H. Borter	T. Melfi
G. R. Cannell	I.-K. Nam
S. Cho	J. B. Ossmann
P. J. Coco	J. E. O'Sullivan
R. H. Davis	M. C. Scott
B. D. Frew	W. J. Sperko
D. W. Gandy	J. R. Stinson
S. E. Gingrich	J. F. Strunk
M. Golliet	W. Windes
L. S. Harbison	R. Wright
R. M. Jessee	S. Yee
J. Johnston, Jr.	H. Michael, <i>Delegate</i>
C. C. Kim	R. W. Barnes, <i>Contributing Member</i>
M. Kris	D. B. Denis, <i>Contributing Member</i>

Working Group on HDPE Materials (SG-MFE) (BPV III)

G. Brouette, <i>Chair</i>	D. P. Munson
M. A. Martin, <i>Secretary</i>	T. M. Musto
M. C. Buckley	S. Patterson
M. Golliet	S. Schuessler
J. Johnston, Jr.	R. Stakenborghs
P. Krishnaswamy	M. Troughton
M. Kuntz	J. Wright
B. Lin	B. Hauger, <i>Contributing Member</i>

Joint ACI-ASME Committee on Concrete Components for Nuclear Service (BPV III)

J. A. Munshi, <i>Chair</i>	T. Muraki
J. McLean, <i>Vice Chair</i>	N. Orbovic
J. Cassamassino, <i>Staff Secretary</i>	J. F. Strunk
C. J. Bang	G. Thomas
L. J. Colarusso	S. Wang
A. C. Eberhardt	A. Adediran, <i>Contributing Member</i>
F. Farzam	J. F. Artuso, <i>Contributing Member</i>
P. S. Ghosal	S. Bae, <i>Contributing Member</i>
B. D. Hovis	J.-B. Domage, <i>Contributing Member</i>
T. C. Inman	B. B. Scott, <i>Contributing Member</i>
C. Jones	M. R. Senecal, <i>Contributing Member</i>
O. Jovall	Z. Shang, <i>Contributing Member</i>
T. Kang	M. Sircar, <i>Contributing Member</i>
N.-H. Lee	C. T. Smith, <i>Contributing Member</i>

Working Group on Design (BPV III-2)

N.-H. Lee, <i>Chair</i>	J. A. Munshi
S. Wang, <i>Vice Chair</i>	T. Muraki
M. Allam	N. Orbovic
S. Bae	J. S. Saini
L. J. Colarusso	G. Thomas
A. C. Eberhardt	A. Istar, <i>Contributing Member</i>
F. Farzam	S.-Y. Kim, <i>Contributing Member</i>
P. S. Ghosal	J. Kwon, <i>Contributing Member</i>
B. D. Hovis	B. B. Scott, <i>Contributing Member</i>
T. C. Inman	Z. Shang, <i>Contributing Member</i>
C. Jones	M. Shin, <i>Contributing Member</i>
O. Jovall	M. Sircar, <i>Contributing Member</i>

Working Group on Materials, Fabrication, and Examination (BPV III-2)

C. Jones, <i>Chair</i>	N.-H. Lee
A. Eberhardt, <i>Vice Chair</i>	Z. Shang
M. Allam	J. F. Strunk
C. J. Bang	I. Zivanovic
B. Birch	A. A. Aboelmagd, <i>Contributing Member</i>
J.-B. Domage	J. F. Artuso, <i>Contributing Member</i>
P. S. Ghosal	B. B. Scott, <i>Contributing Member</i>
T. Kang	

Special Working Group on Modernization (BPV III-2)

N. Orbovic, <i>Chair</i>	S. Wang
J. McLean, <i>Vice Chair</i>	I. Zivanovic
A. Adediran	J.-B. Domage, <i>Contributing Member</i>
O. Jovall	F. Lin, <i>Contributing Member</i>
N. Stoeva	M. A. Ugalde, <i>Contributing Member</i>
A. Varma	

Subgroup on Containment Systems for Spent Nuclear Fuel and High-Level Radioactive Material (BPV III)

G. J. Solovey, <i>Chair</i>	D. Siromani
D. J. Ammerman, <i>Vice Chair</i>	D. B. Spencer
S. Klein, <i>Secretary</i>	J. Wellwood
G. Bjorkman	X. J. Zhai
V. Broz	X. Zhang
D. W. Lewis	D. Dunn, <i>Alternate</i>
E. L. Pleins	W. H. Borter, <i>Contributing Member</i>
A. Rigato	N. M. Simpson, <i>Contributing Member</i>
P. Sakalaukus, Jr.	

Subgroup on Fusion Energy Devices (BPV III)

W. K. Sowder, Jr., <i>Chair</i>	S. Lee
D. Andrei, <i>Staff Secretary</i>	G. Li
D. J. Roszman, <i>Secretary</i>	X. Li
M. Bashir	P. Mokaria
J. P. Blanchard	T. R. Muldoon
L. C. Cadwallader	M. Porton
T. P. Davis	F. J. Schaaf, Jr.
B. R. Doshi	P. Smith
L. El-Guebaly	Y. Song
G. Holtmeier	M. Trosen
D. Johnson	C. Waldon
K. A. Kavanagh	I. J. Zatz
K. Kim	R. W. Barnes, <i>Contributing Member</i>
I. Kimihiro	

Working Group on General Requirements (BPV III-4)

D. J. Roszman, <i>Chair</i>	P. Mokaria
M. Ellis	W. K. Sowder, Jr.

Working Group on In-Vessel Components (BPV III-4)

M. Bashir, <i>Chair</i>	M. Kalsey
Y. Carin	S. T. Madabusi
T. P. Davis	

Working Group on Magnets (BPV III-4)

S. Lee, <i>Chair</i>	K. Kim, <i>Vice Chair</i>
----------------------	---------------------------

Working Group on Materials (BPV III-4)

M. Porton, <i>Chair</i>	P. Mummery
T. P. Davis	

Working Group on Vacuum Vessels (BPV III-4)

I. Kimihiro, <i>Chair</i>	D. Johnson
L. C. Cadwallader	Q. Shijun
B. R. Doshi	Y. Song

Subgroup on High Temperature Reactors (BPV III)

S. Sham, <i>Chair</i>	W. Windes
M. Ando	R. Wright
N. Broom	A. Yeshnik
F. W. Brust	G. L. Zeng
P. Carter	A. Tsigotis, <i>Alternate</i>
M. E. Cohen	D. S. Griffin, <i>Contributing Member</i>
W. J. Geringer	X. Li, <i>Contributing Member</i>
B. F. Hantz	S. Majumdar, <i>Contributing Member</i>
M. H. Jawad	D. L. Marriot, <i>Contributing Member</i>
R. I. Jetter	M. Morishita, <i>Contributing Member</i>
K. Kimura	W. O'Donnell, Sr., <i>Contributing Member</i>
G. H. Koo	L. Shi, <i>Contributing Member</i>
A. Mann	R. W. Swindeman, <i>Contributing Member</i>
M. C. Messner	
X. Wei	

Working Group on Nonmetallic Design and Materials (SG-HTR) (BPV III)

W. Windes, <i>Chair</i>	M. G. Jenkins
W. J. Geringer, <i>Vice Chair</i>	Y. Katoh
A. Appleton	J. Lang
T. D. Burchell	M. N. Mitchell
S.-H. Chi	J. B. Ossmann
V. Chugh	A. Yeshnik
S. T. Gonczy	G. L. Zeng
K. Harris	

Special Working Group on High Temperature Reactor Stakeholders (SG-HTR) (BPV III)

M. E. Cohen, <i>Chair</i>	S. Sham
M. Arcaro	B. Song
R. W. Barnes	X. Wei
N. Broom	A. Yeshnik
V. Chugh	G. L. Zeng
R. A. Fleming	T. Asayama, <i>Contributing Member</i>
K. Harris	X. Li, <i>Contributing Member</i>
R. I. Jetter	M. Morishita, <i>Contributing Member</i>
Y. W. Kim	L. Shi, <i>Contributing Member</i>
G. H. Koo	G. Wu, <i>Contributing Member</i>
K. J. Noel	

Seismic Design Steering Committee (BPV III)

T. M. Adams, <i>Chair</i>	G. H. Koo
F. G. Abatt, <i>Secretary</i>	V. Kostarev
G. A. Antaki	A. Maekawa
C. Basavaraju	K. Matsunaga
A. Berkovsky	R. M. Pace
D. Chowdhury	D. Watkins
R. Döring	

Argentina International Working Group (BPV III)

J. Fernández, <i>Chair</i>	S. A. Echeverria
A. Politi, <i>Vice Chair</i>	E. P. Fresquet
O. Martinez, <i>Staff Secretary</i>	M. M. Gamizo
A. Gomez, <i>Secretary</i>	I. M. Guerreiro
A. Acrogliano	I. A. Knorr
W. Agrelo	M. F. Liendo
G. O. Anteri	D. E. Matthews
M. Anticoli	L. R. Miño
C. A. Araya	J. Monte
J. P. Balbiani	R. L. Morard
A. A. Betervide	A. E. Pastor
D. O. Bordato	E. Pizzichini
G. Bourguigne	J. L. Racamato
M. L. Cappella	H. C. Sanzi
A. Claus	G. J. Scian
R. G. Cocco	G. G. Sebastian
A. Coleff	M. E. Szarko
A. J. Dall'Osto	P. N. Torano
L. M. De Barberis	A. Turrin
D. P. Delfino	O. A. Verastegui
D. N. Dell'Erba	M. D. Vigliano
F. G. Diez	P. Yamamoto
A. Dominguez	M. Zunino

China International Working Group (BPV III)

J. Yan, <i>Chair</i>	C. Peiyin
W. Tang, <i>Vice Chair</i>	Z. Sun
Y. He, <i>Secretary</i>	G. Tang
L. Guo	L. Ting
Y. Jing	Y. Tu
D. Kang	Y. Wang
Y. Li	H. Wu
B. Liang	S. Xue
H. Lin	Z. Yin
S. Liu	D. Yuangang
W. Liu	G. Zhang
J. Ma	W. Zhang
K. Mao	Y. Zhong
D. E. Matthews	Z. Zhong
W. Pei	

Germany International Working Group (BPV III)

J. Wendt, <i>Chair</i>	H.-W. Lange
D. Koelbl, <i>Vice Chair</i>	T. Ludwig
R. Gersinska, <i>Secretary</i>	X. Pitoiset
P. R. Donavin	M. Reichert
R. Döring	G. Roos
C. G. Frantescu	J. Rudolph
A. Huber	L. Sybert
R. E. Hueggenberg	I. Tewes
C. Huttner	R. Tiete
E. Iacopetta	R. Trieglaff
M. H. Koeppen	F. Wille
C. Kuschke	S. Zickler

India International Working Group (BPV III)

R. N. Sen, <i>Chair</i>	A. Johori
S. B. Parkash, <i>Vice Chair</i>	D. Kulkarni
A. D. Bagdare, <i>Secretary</i>	R. Kumar
S. Aithal	D. Narain
S. Benhur	E. L. Pleins
N. M. Borwankar	V. Sehgal
M. Brijlani	S. Singh
H. Dalal	B. K. Sreedhar
S. K. Goyal	

Korea International Working Group (BPV III)

G. H. Koo, <i>Chair</i>	D. Kwon
O.-S. Kim, <i>Secretary</i>	B. Lee
H. Ahn	D. Lee
S. Cho	S. Lee
G.-S. Choi	S.-G. Lee
S. Choi	H. Lim
J. Y. Hong	I.-K. Nam
N.-S. Huh	C.-K. Oh
J.-K. Hwang	C.-Y. Oh
S. S. Hwang	E.-J. Oh
C. Jang	C. Park
I. I. Jeong	H. Park
S. H. Kang	J.-S. Park
J.-I. Kim	Y. S. Pyun
J.-S. Kim	T. Shin
M.-W. Kim	S. Song
S.-S. Kim	W. J. Sperko
Y.-B. Kim	J. S. Yang
Y.-S. Kim	O. Yoo

United Kingdom International Working Group (BPV III)

C. D. Bell, <i>Chair</i>	G. Innes
P. M. James, <i>Vice Chair</i>	S. A. Jones
C. B. Carpenter, <i>Secretary</i>	B. Pellereau
T. Bann	C. R. Schneider
M. J. Chevalier	J. W. Stairmand
M. Consonni	J. Sulley
M. J. Crathorne	J. Talamantes-Silva

Special Working Group on Editing and Review (BPV III)

D. E. Matthews, <i>Chair</i>	S. Hunter
R. P. Deubler	J. C. Minichiello
A. C. Eberhardt	J. F. Strunk
J. V. Gardiner	C. Wilson

Special Working Group on HDPE Stakeholders (BPV III)

M. Brandes, <i>Chair</i>	D. P. Munson
S. Patterson, <i>Secretary</i>	T. M. Musto
S. Choi	J. E. O'Sullivan
C. M. Faigy	V. Rohatgi
M. Golliet	F. J. Schaaaf, Jr.
R. M. Jessee	R. Stakenborghs
J. Johnston, Jr.	M. Troughton
M. Kuntz	J. Wright
M. Lashley	C. Lin, <i>Alternate</i>
K. A. Manoly	D. Burwell, <i>Contributing Member</i>

Special Working Group on Honors and Awards (BPV III)

J. C. Minichiello, <i>Chair</i>	R. M. Jessee
A. Appleton	D. E. Matthews
R. W. Barnes	

Special Working Group on Industry Experience for New Plants (BPV III & BPV XI)

J. T. Lindberg, <i>Chair</i>	O.-S. Kim
J. B. Ossmann, <i>Chair</i>	K. Matsunaga
M. C. Buckley, <i>Secretary</i>	D. E. Matthews
A. Cardillo	R. E. McLaughlin
T. L. Chan	D. W. Sandusky
P. J. Hennessey	R. M. Wilson
D. O. Henry	S. M. Yee
J. Honcharik	A. Tsigotis, <i>Alternate</i>
C. G. Kim	

Special Working Group on International Meetings and IWG Liaisons (BPV III)

D. E. Matthews, <i>Chair</i>	R. L. Crane
K. Verderber, <i>Staff Secretary</i>	P. R. Donavin
T. M. Adams	E. L. Pleins
R. W. Barnes	W. J. Sperko
T. D. Burchell	

Special Working Group on New Plant Construction Issues (BPV III)

E. L. Pleins, <i>Chair</i>	R. R. Stevenson
M. C. Scott, <i>Secretary</i>	M. L. Wilson
A. Cardillo	H. Xu
P. J. Coco	J. Yan
J. Honcharik	N. J. Hansing, <i>Alternate</i>
O.-S. Kim	J. C. Minichiello, <i>Contributing Member</i>
M. Kris	
D. W. Sandusky	K. Verderber, <i>Contributing Member</i>

COMMITTEE ON HEATING BOILERS (BPV IV)

J. A. Hall, <i>Chair</i>	M. Mengon
T. L. Bedeaux, <i>Vice Chair</i>	P. A. Molvie
C. R. Ramcharran, <i>Staff Secretary</i>	R. D. Troutt
L. Badziagowski	M. Wadkinson
B. Calderon	R. V. Wielgoszinski
J. P. Chicoine	H. Michael, <i>Delegate</i>
J. M. Downs	D. Picart, <i>Delegate</i>
J. L. Kleiss	D. Nelson, <i>Alternate</i>
J. Klug	S. V. Voorhees, <i>Contributing Member</i>

Subgroup on Care and Operation of Heating Boilers (BPV IV)

R. D. Troutt, <i>Chair</i>	J. A. Hall
C. R. Ramcharran, <i>Staff Secretary</i>	J. L. Kleiss
B. Ahee	P. A. Molvie
T. L. Bedeaux	M. Wadkinson
J. M. Downs	

Subgroup on Cast Boilers (BPV IV)

J. P. Chicoine, <i>Chair</i>	J. A. Hall
J. M. Downs, <i>Vice Chair</i>	J. L. Kleiss
C. R. Ramcharran, <i>Staff Secretary</i>	M. Mengon
T. L. Bedeaux	

Subgroup on Materials (BPV IV)

M. Wadkinson, <i>Chair</i>	L. Badziagowski
J. M. Downs, <i>Vice Chair</i>	T. L. Bedeaux
C. R. Ramcharran, <i>Staff Secretary</i>	J. A. Hall

Subgroup on Water Heaters (BPV IV)

L. Badziagowski, <i>Chair</i>	C. Dinic
J. L. Kleiss, <i>Vice Chair</i>	B. J. Iske
C. R. Ramcharran, <i>Staff Secretary</i>	P. A. Molvie
B. Ahee	T. E. Trant
J. P. Chicoine	R. D. Troutt

Subgroup on Welded Boilers (BPV IV)

T. L. Bedeaux, <i>Chair</i>	M. Mengon
J. L. Kleiss, <i>Vice Chair</i>	P. A. Molvie
C. R. Ramcharran, <i>Staff Secretary</i>	R. D. Troutt
B. Ahee	M. Wadkinson
L. Badziagowski	R. V. Wielgoszinski
B. Calderon	D. Nelson, <i>Alternate</i>
C. Dinic	

COMMITTEE ON NONDESTRUCTIVE EXAMINATION (BPV V)

N. A. Finney, <i>Chair</i>	B. D. Laite
C. May, <i>Vice Chair</i>	L. E. Mullins
C. R. Ramcharran, <i>Staff Secretary</i>	T. L. Plasek
D. Bajula	P. B. Shaw
J. Bennett	C. Vorwald
P. L. Brown	G. M. Gatti, <i>Delegate</i>
M. A. Burns	S. J. Akryn, <i>Contributing Member</i>
N. Carter	J. E. Batey, <i>Contributing Member</i>
T. Clausing	A. S. Birks, <i>Contributing Member</i>
C. Emslander	N. Y. Faransso, <i>Contributing Member</i>
A. F. Garbolevsky	R. W. Kruzic, <i>Contributing Member</i>
J. F. Halley	F. J. Sattler, <i>Contributing Member</i>
P. T. Hayes	H. C. Graber, <i>Honorary Member</i>
G. W. Hembree	O. F. Hedden, <i>Honorary Member</i>
F. B. Kovacs	J. R. MacKay, <i>Honorary Member</i>
K. Krueger	T. G. McCarty, <i>Honorary Member</i>

Executive Committee (BPV V)

C. May, <i>Chair</i>	J. F. Halley
N. A. Finney, <i>Vice Chair</i>	P. T. Hayes
C. R. Ramcharran, <i>Staff Secretary</i>	G. W. Hembree
N. Carter	F. B. Kovacs
C. Emslander	C. Vorwald
V. F. Godinez-Azuaga	

Subgroup on General Requirements/Personnel Qualifications and Inquiries (BPV V)

C. Emslander, <i>Chair</i>	F. B. Kovacs
D. I. Morris, <i>Vice Chair</i>	K. Krueger
J. Bennett	C. May
N. Carter	C. Vorwald
T. Clausing	S. J. Akryn, <i>Contributing Member</i>
N. A. Finney	J. E. Batey, <i>Contributing Member</i>
J. F. Halley	N. Y. Faransso, <i>Contributing Member</i>
G. W. Hembree	J. P. Swezy, Jr., <i>Contributing Member</i>

Subgroup on Surface Examination Methods (BPV V)

N. Carter, <i>Chair</i>	L. E. Mullins
B. D. Laite, <i>Vice Chair</i>	P. B. Shaw
P. L. Brown	C. Vorwald
T. Clausing	C. Wassink
C. Emslander	D. M. Woodward
N. Farenbaugh	G. M. Gatti, <i>Delegate</i>
N. A. Finney	S. J. Akryn, <i>Contributing Member</i>
J. F. Halley	J. E. Batey, <i>Contributing Member</i>
K. Hayes	N. Y. Faransso, <i>Contributing Member</i>
G. W. Hembree	R. W. Kruzic, <i>Contributing Member</i>
C. May	F. J. Sattler, <i>Contributing Member</i>

Subgroup on Volumetric Methods (BPV V)

C. May, *Chair*
 J. F. Halley, *Vice Chair*
 D. Adkins
 P. L. Brown
 N. A. Finney
 A. F. Garbolevsky
 R. W. Hardy
 P. T. Hayes
 G. W. Hembree
 F. B. Kovacs
 K. Krueger

L. E. Mullins
 E. Peloquin
 T. L. Plasek
 C. Vorwald
 G. M. Gatti, *Delegate*
 S. J. Akryn, *Contributing Member*
 J. E. Batey, *Contributing Member*
 N. Y. Faransso, *Contributing Member*
 R. W. Kruzic, *Contributing Member*
 F. J. Sattler, *Contributing Member*

Special Working Group on Advanced Ultrasonic Testing Techniques (BPV V)

L. E. Mullins, *Chair*
 K. Krueger, *Vice Chair*
 D. Adkins
 D. Bajula
 N. A. Finney
 J. L. Garner
 J. F. Halley

P. T. Hayes
 M. Lozev
 E. Peloquin
 M. Sens
 D. Tompkins
 C. Wassink

Working Group on Full Matrix Capture (FMC) (BPV V)

P. T. Hayes, *Chair*
 E. Peloquin, *Vice Chair*
 D. Adkins
 D. Bajula
 D. Bellistri
 J. Catty
 N. A. Finney
 J. L. Garner
 V. F. Godinez-Azcuaga
 R. T. Grotenhuis
 J. F. Halley

K. Hayes
 G. W. Hembree
 K. Krueger
 M. Lozev
 L. E. Mullins
 D. Richard
 M. Sens
 D. Tompkins
 O. Volf
 C. Wassink

Working Group on Acoustic Emissions (SG-VM) (BPV V)

V. F. Godinez-Azcuaga, *Chair*
 S. R. Doctor, *Vice Chair*
 J. Catty
 N. F. Douglas, Jr.

R. K. Miller
 L. Zhang
 J. E. Batey, *Contributing Member*
 N. Y. Faransso, *Contributing Member*

Working Group on Computed Tomography (BPV V)

C. May, *Chair*
 T. L. Clifford
 R. W. Hardy
 G. W. Hembree
 F. B. Kovacs

R. J. Mills
 T. L. Plasek
 C. Vorwald
 B. White
 L. E. Mullins, *Contributing Member*

Working Group on Radiography (SG-VM) (BPV V)

C. Vorwald, *Chair*
 D. M. Woodward, *Vice Chair*
 J. Anderson
 P. L. Brown
 C. Emslander
 A. F. Garbolevsky
 R. W. Hardy
 G. W. Hembree
 F. B. Kovacs
 B. D. Laite

C. May
 R. J. Mills
 T. L. Plasek
 T. Vidimos
 B. White
 S. J. Akryn, *Contributing Member*
 J. E. Batey, *Contributing Member*
 N. Y. Faransso, *Contributing Member*
 R. W. Kruzic, *Contributing Member*

Working Group on Ultrasonics (SG-VM) (BPV V)

J. F. Halley, *Chair*
 K. Krueger, *Vice Chair*
 D. Adkins
 D. Bajula
 C. Brown
 C. Emslander
 N. A. Finney
 P. T. Hayes
 G. W. Hembree
 B. D. Laite
 C. May
 L. E. Mullins
 E. Peloquin
 M. J. Quarry

D. Tompkins
 D. Van Allen
 J. Vinyard
 C. Vorwald
 C. Wassink
 D. Alleyne, *Contributing Member*
 J. E. Batey, *Contributing Member*
 N. Y. Faransso, *Contributing Member*
 R. W. Kruzic, *Contributing Member*
 G. M. Light, *Contributing Member*
 P. Mudge, *Contributing Member*
 F. J. Sattler, *Contributing Member*
 J. Vanvelsor, *Contributing Member*

Italy International Working Group (BPV V)

P. L. Dinelli, *Chair*
 D. D. Raimander, *Secretary*
 M. Agostini
 T. Aldo
 F. Bresciani
 G. Campos
 N. Caputo
 M. Colombo
 F. Ferrarese
 E. Ferrari

M. A. Grimoldi
 G. Luoni
 O. Oldani
 U. Papponetti
 P. Pedersoli
 A. Veroni
 M. Zambon
 V. Calo, *Contributing Member*
 G. Gobbi, *Contributing Member*
 G. Pontiggia, *Contributing Member*

COMMITTEE ON PRESSURE VESSELS (BPV VIII)

S. C. Roberts, *Chair*
 M. D. Lower, *Vice Chair*
 J. Oh, *Staff Secretary*
 S. J. Rossi, *Staff Secretary*
 G. Auriolos, Sr.
 S. R. Babka
 R. J. Basile
 P. Chavdarov
 D. B. DeMichael
 J. F. Grubb
 B. F. Hantz
 M. Kowalczyk
 D. L. Kurlle
 R. Mahadeen
 S. A. Marks
 P. Matkovic
 R. W. Mikitka
 B. R. Morelock
 T. P. Pastor
 D. T. Peters
 M. J. Pischke
 M. D. Rana
 G. B. Rawls, Jr.
 F. L. Richter
 C. D. Rodery

J. C. Sowinski
 D. Srnica
 D. B. Stewart
 P. L. Sturgill
 K. Subramanian
 D. A. Swanson
 J. P. Swezy, Jr.
 S. Terada
 E. Uptis
 A. Viet
 K. Xu
 P. A. McGowan, *Delegate*
 H. Michael, *Delegate*
 K. Oyamada, *Delegate*
 M. E. Papponetti, *Delegate*
 X. Tang, *Delegate*
 A. Chaudouet, *Contributing Member*
 J. P. Glaspie, *Contributing Member*
 W. S. Jacobs, *Contributing Member*
 K. T. Lau, *Contributing Member*
 U. R. Miller, *Contributing Member*
 K. Mokhtarian, *Contributing Member*
 G. G. Karcher, *Honorary Member*
 K. K. Tam, *Honorary Member*

Executive Committee (BPV VIII)

M. D. Lower, *Chair*
 S. J. Rossi, *Staff Secretary*
 G. Auriolos, Sr.
 M. Kowalczyk
 S. A. Marks
 P. Matkovic

F. L. Richter
 S. C. Roberts
 J. C. Sowinski
 K. Subramanian
 A. Viet
 K. Xu

Subgroup on Design (BPV VIII)

J. C. Sowinski, *Chair*
 C. S. Hinson, *Vice Chair*
 G. Auriolles, Sr.
 S. R. Babka
 O. A. Barsky
 R. J. Basile
 D. Chandiramani
 M. Faulkner
 B. F. Hantz
 C. E. Hinnant
 M. H. Jawad
 S. Krishnamurthy
 D. L. Kurle
 K. Kescu
 M. D. Lower
 R. W. Mikitka
 B. Millet
 M. D. Rana
 G. B. Rawls, Jr.

S. C. Roberts
 C. D. Rodery
 T. G. Seipp
 D. Srnic
 D. A. Swanson
 S. Terada
 J. Vattappilly
 K. Xu
 K. Oyamada, *Delegate*
 M. E. Papponetti, *Delegate*
 W. S. Jacobs, *Contributing Member*
 P. K. Lam, *Contributing Member*
 K. Mokhtarian, *Contributing Member*
 T. P. Pastor, *Contributing Member*
 S. C. Shah, *Contributing Member*
 K. K. Tam, *Contributing Member*
 E. Upitis, *Contributing Member*
 Z. Wang, *Contributing Member*

Working Group on Design-By-Analysis (BPV VIII)

B. F. Hantz, *Chair*
 T. W. Norton, *Secretary*
 D. A. Arnett
 J. Bedoya
 S. Guzey
 C. F. Heberling II
 C. E. Hinnant
 M. H. Jawad
 S. Kataoka
 S. Kilambi
 K. D. Kirkpatrick

S. Krishnamurthy
 A. Mann
 C. Nadarajah
 P. Prueter
 T. G. Seipp
 M. A. Shah
 S. Terada
 R. G. Brown, *Contributing Member*
 D. Dewees, *Contributing Member*
 K. Saboda, *Contributing Member*

Working Group on Elevated Temperature Design (BPV I and VIII)

A. Mann, *Chair*
 C. Nadarajah, *Secretary*
 D. Anderson
 D. Dewees
 B. F. Hantz
 M. H. Jawad
 R. I. Jetter
 S. Krishnamurthy
 T. Le

M. C. Messner
 M. N. Mitchell
 P. Prueter
 M. J. Swindeman
 J. P. Glaspie, *Contributing Member*
 D. L. Marriott, *Contributing Member*
 N. McMurray, *Contributing Member*
 B. J. Mollitor, *Contributing Member*

Subgroup on Fabrication and Examination (BPV VIII)

S. A. Marks, *Chair*
 D. I. Morris, *Vice Chair*
 T. Halligan, *Secretary*
 N. Carter
 J. Lu
 B. R. Morelock
 O. Mulet
 M. J. Pischke
 M. J. Rice
 J. Roberts
 C. D. Rodery
 B. F. Shelley
 D. Smith

P. L. Sturgill
 J. P. Swezy, Jr.
 E. Upitis
 C. Violand
 E. A. Whittle
 K. Oyamada, *Delegate*
 W. J. Bees, *Contributing Member*
 L. F. Campbell, *Contributing Member*
 J. Lee, *Contributing Member*
 J. Si, *Contributing Member*
 R. Uebel, *Contributing Member*
 X. Xue, *Contributing Member*
 B. Yang, *Contributing Member*

Subgroup on General Requirements (BPV VIII)

F. L. Richter, *Chair*
 M. Faulkner, *Vice Chair*
 J. Hoskinson, *Secretary*
 N. Barkley
 R. J. Basile
 T. P. Beirne
 D. T. Davis
 D. B. DeMichael
 M. D. Lower
 T. P. Pastor
 D. K. Peetz

G. B. Rawls, Jr.
 S. C. Roberts
 J. C. Sowinski
 P. Speranza
 D. Srnic
 D. B. Stewart
 D. A. Swanson
 R. Uebel
 J. P. Glaspie, *Contributing Member*
 Z. Wang, *Contributing Member*
 Y. Yang, *Contributing Member*

Task Group on Fired Heater Pressure Vessels (BPV VIII)

J. Hoskinson, *Chair*
 J. Bradley
 W. Kim
 S. Kirk
 D. Nelson
 T. P. Pastor

R. Robles
 J. Rust
 P. Shanks
 E. Smith
 D. Srnic
 J. P. Swezy, Jr.

Task Group on Subsea Applications (BPV VIII)

M. Sarzynski, *Chair*
 A. J. Grohmann, *Vice Chair*
 L. P. Antalffy
 R. C. Biel
 J. Ellens
 J. Hademenos
 J. Kaculi
 K. Karpanan
 F. Kirkemo
 C. Lan

P. Lutkiewicz
 N. McKie
 S. K. Parimi
 R. H. Patil
 J. R. Sims
 M. P. Vaclavik
 R. Cordes, *Contributing Member*
 S. Krishna, *Contributing Member*
 D. T. Peters, *Contributing Member*

Task Group on UG-20(f) (BPV VIII)

S. Krishnamurthy, *Chair*
 T. L. Anderson
 K. E. Bagnoli
 R. P. Deubler
 B. F. Hantz

B. R. Macejko
 J. Penso
 M. Prager
 M. D. Rana

Subgroup on Heat Transfer Equipment (BPV VIII)

P. Matkovic, *Chair*
 M. D. Clark, *Vice Chair*
 L. Bower, *Secretary*
 G. Auriolles, Sr.
 S. R. Babka
 J. H. Barbee
 O. A. Barsky
 T. Bunyarattaphant
 A. Chaudouet
 D. L. Kurle
 R. Mahadeen

S. Mayeux
 S. Neilsen
 E. Smith
 A. M. Voytko
 R. P. Wiberg
 I. G. Campbell, *Contributing Member*
 G. G. Karcher, *Contributing Member*
 J. Pasek, *Contributing Member*
 D. Srnic, *Contributing Member*
 Z. Tong, *Contributing Member*

Working Group on Plate Heat Exchangers (BPV VIII)

P. Matkovic, *Chair*
 S. R. Babka
 J. F. Grubb
 V. Gudge
 R. Mahadeen
 S. A. Marks

D. I. Morris
 M. J. Pischke
 E. Smith
 D. Srnic
 S. Sullivan

Subgroup on High Pressure Vessels (BPV VIII)

K. Subramanian, *Chair*
M. Sarzynski, *Vice Chair*
A. P. Maslowski, *Staff Secretary*
L. P. Antalffy
R. C. Biel
P. N. Chaku
L. Fridlund
R. T. Hallman
K. Karpanan
J. Keltjens
A. K. Khare
G. M. Mital
G. T. Nelson
M. Parr
D. T. Peters
E. A. Rodriguez
E. D. Roll
J. R. Sims
E. Smith
F. W. Tatar
S. Terada

C. Tipple
R. Wink
Y. Xu
A. M. Clayton, *Contributing Member*
R. Cordes, *Contributing Member*
R. D. Dixon, *Contributing Member*
Q. Dong, *Contributing Member*
T. A. Duffey, *Contributing Member*
D. Fuenmayor, *Contributing Member*
R. M. Hoshman, *Contributing Member*
Y. Huang, *Contributing Member*
F. Kirkemo, *Contributing Member*
R. A. Leishear, *Contributing Member*
C. Romero, *Contributing Member*
K.-J. Young, *Contributing Member*
D. J. Burns, *Honorary Member*
D. M. Fryer, *Honorary Member*
G. J. Mraz, *Honorary Member*
E. H. Perez, *Honorary Member*

Subgroup on Materials (BPV VIII)

M. Kowalczyk, *Chair*
J. Cameron, *Vice Chair*
S. Kilambi, *Secretary*
P. Chavdarov
J. F. Grubb
D. Maitra
D. W. Rahoi
J. Robertson
R. C. Sutherland
E. Uptis
K. Xu

S. Yem
A. Di Rienzo, *Contributing Member*
J. D. Fritz, *Contributing Member*
M. Katcher, *Contributing Member*
W. M. Lundy, *Contributing Member*
J. A. McMaster, *Contributing Member*
J. Penso, *Contributing Member*
B. Pletcher, *Contributing Member*
P. G. Wittenbach, *Contributing Member*
X. Wu, *Contributing Member*

Subgroup on Toughness (BPV VIII)

K. Xu, *Chair*
T. Halligan, *Vice Chair*
N. Carter
C. S. Hinson
W. S. Jacobs
S. Kilambi
D. L. Kurle
M. D. Rana
F. L. Richter
K. Subramanian

D. A. Swanson
J. P. Swezy, Jr.
S. Terada
E. Uptis
J. Vattappilly
K. Oyamada, *Delegate*
S. Krishnamurthy, *Contributing Member*
K. Mokhtarian, *Contributing Member*

Subgroup on Graphite Pressure Equipment (BPV VIII)

A. Viet, *Chair*
C. W. Cary, *Vice Chair*
G. C. Becherer
F. L. Brown
R. J. Bulgin

J. D. Clements
H. Lee, Jr.
T. Rudy
A. A. Stupica

Argentina International Working Group (BPV VIII)

A. Dominguez, *Chair*
F. P. Larrosa, *Secretary*
M. M. Acosta
R. A. Barey
C. Alderetes
F. A. Andres
L. F. Boccanera
O. S. Bretones
A. Burgueno
G. Casanas
D. H. Da Rold
J. I. Duo
M. Favareto

M. D. Kuhn
L. M. Leccese
C. Meinl
M. A. Mendez
J. J. Monaco
M. A. A. Pipponzi
D. Rizzo
R. Robles
J. C. Rubeo
S. Schamun
G. Telleria
M. M. C. Tocco

China International Working Group (BPV VIII)

X. Chen, *Chair*
B. Shou, *Vice Chair*
Z. Fan, *Secretary*
Y. Chen
Z. Chen
J. Cui
R. Duan
W. Guo
B. Han
J. Hu
Q. Hu
H. Hui
D. Luo
Y. Luo

C. Miao
X. Qian
L. Sun
B. Wang
C. Wu
F. Xu
F.-Z. Xuan
Y. Yang
K. Zhang
Yanfeng Zhang
Yijun Zhang
S. Zhao
J. Zheng
G. Zhu

Germany International Working Group (BPV VIII)

P. Chavdarov, *Chair*
M. Sykora, *Vice Chair*
B. Daume
A. Emrich
J. Fleischfresser
R. Helmholdt
R. Kauer
D. Koelbl
S. Krebs

T. Ludwig
R. A. Meyers
H. Michael
S. Reich
A. Spangenberg
G. Naumann, *Contributing Member*
P. Paluszkiwicz, *Contributing Member*
R. Uebel, *Contributing Member*

India International Working Group (BPV VIII)

D. Chandiramani, *Chair*
D. Kulkarni, *Vice Chair*
A. D. Dalal, *Secretary*
P. Arulkumar
B. Basu
P. Gandhi
S. K. Goyal
V. Jayabalan
A. Kakumanu
V. V. P. Kumar

T. Mukherjee
P. C. Pathak
S. B. Patil
D. Prabhu
A. Sadasivam
M. P. Shah
R. Tiru
V. T. Valavan
M. Sharma, *Contributing Member*

Italy International Working Group (BPV VIII)

A. Teli, *Chair*
D. D. Raimander, *Secretary*
B. G. Alborali
P. Aliprandi
A. Avogadri
A. Camanni
M. Colombo
P. Conti
D. Cortassa
P. L. Dinelli
F. Finco

M. Guglielmetti
A. F. Magri
P. Mantovani
M. Millefanti
L. Moracchioli
P. Pacor
G. Pontiggia
S. Sarti
A. Veroni
G. Gobbi, *Contributing Member*

Special Working Group on Bolted Flanged Joints (BPV VIII)

R. W. Mikitka, *Chair*
G. Auriolles, Sr.
D. Bankston, Jr.
W. Brown
H. Chen
A. Mann

W. McDaniel
M. Osterfoss
J. R. Payne
G. B. Rawls, Jr.
R. Wacker

Subgroup on Interpretations (BPV VIII)

G. Auriolles, Sr., *Chair*
J. Oh, *Staff Secretary*
S. R. Babka
J. Cameron
N. Carter
C. W. Cary
B. F. Hantz
M. Kowalczyk
D. L. Kurle
M. D. Lower
A. Mann
S. A. Marks
P. Matkovic
G. M. Mital
D. I. Morris
D. T. Peters
F. L. Richter
S. C. Roberts

C. D. Rodery
T. G. Seipp
J. C. Sowinski
D. B. Stewart
D. A. Swanson
J. P. Swezy, Jr.
J. Vattappilly
A. Viet
K. Xu
R. J. Basile, *Contributing Member*
D. B. DeMichael, *Contributing Member*
R. D. Dixon, *Contributing Member*
S. Kilambi, *Contributing Member*
R. Mahadeen, *Contributing Member*
T. P. Pastor, *Contributing Member*
P. L. Sturgill, *Contributing Member*

COMMITTEE ON WELDING, BRAZING, AND FUSING (BPV IX)

D. A. Bowers, *Chair*
M. J. Pischke, *Vice Chair*
E. Lawson, *Staff Secretary*
M. Bernasek
M. A. Boring
J. G. Feldstein
P. D. Flenner
S. E. Gingrich
K. L. Hayes
R. M. Jessee
J. S. Lee
W. M. Lundy
S. A. Marks
T. Melfi
W. F. Newell, Jr.
D. K. Peetz
E. G. Reichelt
M. J. Rice

M. B. Sims
W. J. Sperko
P. L. Sturgill
J. P. Swezy, Jr.
E. W. Woelfel
D. Pojatar, *Delegate*
A. Roza, *Delegate*
M. Consonni, *Contributing Member*
S. A. Jones, *Contributing Member*
S. Raghunathan, *Contributing Member*
M. J. Stanko, *Contributing Member*
P. L. Van Fosson, *Contributing Member*
R. K. Brown, Jr., *Honorary Member*
M. L. Carpenter, *Honorary Member*
B. R. Newmark, *Honorary Member*
S. D. Reynolds, Jr., *Honorary Member*

Subgroup on Brazing (BPV IX)

S. A. Marks, *Chair*
E. W. Beckman
A. F. Garbolevsky
N. Mohr

A. R. Nywening
M. J. Pischke
J. P. Swezy, Jr.

Subgroup on General Requirements (BPV IX)

P. L. Sturgill, *Chair*
N. Carter, *Vice Chair*
S. A. Marks, *Secretary*
J. P. Bell
D. A. Bowers
P. Gilston
M. Heinrichs
A. Howard
R. M. Jessee

D. K. Peetz
H. B. Porter
J. P. Swezy, Jr.
E. W. Woelfel
E. Molina, *Delegate*
E. W. Beckman, *Contributing Member*
B. R. Newmark, *Honorary Member*

Subgroup on Materials (BPV IX)

M. Bernasek, *Chair*
T. Anderson
E. Cutlip
M. Denault
S. E. Gingrich
L. S. Harbison
M. James
R. M. Jessee
T. Melfi
S. D. Nelson

M. J. Pischke
A. Roza
C. E. Sainz
P. L. Sturgill
C. Zanfir
V. G. V. Giunto, *Delegate*
D. J. Kotecki, *Contributing Member*
B. Krueger, *Contributing Member*
W. J. Sperko, *Contributing Member*
M. J. Stanko, *Contributing Member*

Subgroup on Plastic Fusing (BPV IX)

E. W. Woelfel, *Chair*
D. Burwell
K. L. Hayes
R. M. Jessee
J. Johnston, Jr.
J. E. O'Sullivan

E. G. Reichelt
M. J. Rice
S. Schuessler
M. Troughton
C. Violand
J. Wright

Subgroup on Strength of Weldments (BPV II and IX)

G. W. Galanes, *Chair*
K. L. Hayes, *Vice Chair*
S. H. Bowes, *Secretary*
K. K. Coleman
M. Denault
J. R. Foulds
D. W. Gandy
M. Ghahremani
J. Henry
W. F. Newell, Jr.

J. Penso
D. W. Rahoo
B. Roberts
W. J. Sperko
J. P. Swezy, Jr.
M. Ueyama
A. A. Amiri, *Contributing Member*
P. D. Flenner, *Contributing Member*
J. J. Sanchez-Hanton, *Contributing Member*

Subgroup on Welding Qualifications (BPV IX)

M. J. Rice, <i>Chair</i>	B. R. Newton
J. S. Lee, <i>Vice Chair</i>	E. G. Reichelt
K. L. Hayes, <i>Secretary</i>	M. B. Sims
M. Bernasek	W. J. Sperko
M. A. Boring	S. A. Sprague
D. A. Bowers	P. L. Sturgill
R. Campbell	J. P. Swezy, Jr.
R. B. Corbit	C. Violand
P. D. Flenner	A. D. Wilson
L. S. Harbison	D. Chandiramani, <i>Contributing Member</i>
M. Heinrichs	M. Consonni, <i>Contributing Member</i>
W. M. Lundy	M. Dehghan, <i>Contributing Member</i>
D. W. Mann	T. C. Wiesner, <i>Contributing Member</i>
T. Melfi	
W. F. Newell, Jr.	

Argentina International Working Group (BPV IX)

A. Burgueno, <i>Chair</i>	J. A. Herrera
E. Lawson, <i>Staff Secretary</i>	M. D. Kuhn
B. Bardott	M. A. Mendez
L. F. Boccanera	A. E. Pastor
M. Favareto	G. Telleria
C. A. Garibotti	M. M. C. Tocco

Germany International Working Group (BPV IX)

P. Chavdarov, <i>Chair</i>	S. Krebs
A. Spangenberg, <i>Vice Chair</i>	T. Ludwig
E. Lawson, <i>Staff Secretary</i>	G. Naumann
P. Thiebo, <i>Secretary</i>	A. Roza
J. Daldrup	K.-G. Toelle
B. Daume	S. Wegener
J. Fleischfresser	F. Wodke
E. Floer	R. Helmholdt

Italy International Working Group (BPV IX)

D. D. Raimander, <i>Chair</i>	L. Moracchioli
M. Bernasek	P. Pacor
A. Camanni	G. Pontiggia
P. L. Dinelli	P. Siboni
F. Ferrarese	A. Volpi
M. Mandina	V. Calo, <i>Contributing Member</i>
A. S. Monastra	G. Gobbi, <i>Contributing Member</i>

Spain International Working Group (BPV IX)

F. J. Q. Pandelo, <i>Chair</i>	F. Manas
F. L. Villabrille, <i>Vice Chair</i>	B. B. Miguel
E. Lawson, <i>Staff Secretary</i>	A. D. G. Munoz
F. R. Hermida, <i>Secretary</i>	A. B. Pascual
C. A. Celimendiz	S. Sevil
M. A. F. Garcia	G. Gobbi, <i>Contributing Member</i>
R. G. Garcia	

COMMITTEE ON FIBER-REINFORCED PLASTIC PRESSURE VESSELS (BPV X)

B. Linnemann, <i>Chair</i>	L. E. Hunt
B. F. Shelley, <i>Vice Chair</i>	D. L. Keeler
P. D. Stumpf, <i>Staff Secretary</i>	D. H. McCauley
A. L. Beckwith	N. L. Newhouse
F. L. Brown	G. Ramirez
J. L. Bustillos	J. R. Richter
B. R. Colley	S. L. Wagner
T. W. Cowley	D. O. Yancey, Jr.
I. L. Dinovo	P. H. Ziehl
D. Eisberg	D. H. Hodgkinson, <i>Contributing Member</i>
M. R. Gorman	
B. Hebb	

COMMITTEE ON NUCLEAR INSERVICE INSPECTION (BPV XI)

R. W. Swayne, <i>Chair</i>	N. A. Palm
S. D. Kulat, <i>Vice Chair</i>	G. C. Park
D. W. Lamond, <i>Vice Chair</i>	A. T. Roberts III
D. Miro-Quesada, <i>Staff Secretary</i>	D. A. Scarth
J. F. Ball	F. J. Schaaf, Jr.
W. H. Bamford	S. Takaya
J. M. Boughman	D. Vetter
C. Brown	T. V. Vo
S. B. Brown	D. E. Waskey
T. L. Chan	J. G. Weicks
R. C. Cipolla	M. Weis
D. R. Cordes	Y.-K. Chung, <i>Delegate</i>
H. Do	C. Ye, <i>Delegate</i>
E. V. Farrell, Jr.	M. L. Benson, <i>Alternate</i>
M. J. Ferlisi	J. K. Loy, <i>Alternate</i>
P. D. Fisher	R. O. McGill, <i>Alternate</i>
T. J. Griesbach	D. J. Shim, <i>Alternate</i>
J. Hakii	A. Udyawar, <i>Alternate</i>
M. L. Hall	E. B. Gerlach, <i>Contributing Member</i>
D. O. Henry	B. R. Newton, <i>Contributing Member</i>
W. C. Holston	C. D. Cowfer, <i>Honorary Member</i>
J. T. Lindberg	D. D. Davis, <i>Honorary Member</i>
G. A. Lofthus	R. E. Gimple, <i>Honorary Member</i>
H. Malikowski	F. E. Gregor, <i>Honorary Member</i>
S. L. McCracken	O. F. Hedden, <i>Honorary Member</i>
S. A. Norman	R. D. Kerr, <i>Honorary Member</i>
C. A. Nove	P. C. Riccardella, <i>Honorary Member</i>
T. Nuoffer	R. A. West, <i>Honorary Member</i>
J. Nygaard	C. J. Wirtz, <i>Honorary Member</i>
J. E. O'Sullivan	R. A. Yonekawa, <i>Honorary Member</i>

Executive Committee (BPV XI)

S. D. Kulat, <i>Chair</i>	S. L. McCracken
R. W. Swayne, <i>Vice Chair</i>	C. A. Nove
D. Miro-Quesada, <i>Staff Secretary</i>	T. Nuoffer
W. H. Bamford	N. A. Palm
M. J. Ferlisi	G. C. Park
D. W. Lamond	A. T. Roberts III
J. T. Lindberg	M. L. Benson, <i>Alternate</i>

Argentina International Working Group (BPV XI)

F. M. Schroeter, <i>Chair</i>	R. J. Lopez
O. Martinez, <i>Staff Secretary</i>	M. Magliocchi
D. A. Cipolla	L. R. Miño
A. Claus	J. Monte
D. Costa	M. D. Pereda
D. P. Delfino	A. Politi
D. N. Dell'Erba	C. G. Real
A. Dominguez	F. J. Schaaf, Jr.
S. A. Echeverria	G. J. Scian
E. P. Fresquet	M. J. Solari
M. M. Gamizo	P. N. Torano
I. M. Guerreiro	P. Yamamoto
F. Llorente	

China International Working Group (BPV XI)

J. H. Liu, <i>Chair</i>	S. Shuo
Y. Nie, <i>Vice Chair</i>	Y. Sixin
C. Ye, <i>Vice Chair</i>	Y. X. Sun
M. W. Zhou, <i>Secretary</i>	G. X. Tang
J. F. Cai	Q. Wang
H. Chen	Q. W. Wang
H. D. Chen	Z. S. Wang
Y. Cheng	L. Xing
Y. B. Guo	F. Xu
Y. Hongqi	S. X. Xu
D. R. Horn	Q. Yin
Y. Hou	K. Zhang
S. X. Lin	Y. Zhe
W. N. Pei	Z. M. Zhong
L. Shiwei	

German International Working Group (BPV XI)

R. Döring, <i>Chair</i>	N. Legl
R. Trieglaff, <i>Vice Chair</i>	T. Ludwig
R. Piel, <i>Secretary</i>	X. Pitoiset
A. Casse	M. Reichert
S. Dugan	L. Sybertz
C. G. Frantescu	I. Tewes
M. Hagenbruch	R. Tiete
E. Iacopetta	J. Wendt
S. D. Kulat	S. Zickler
H.-W. Lange	

India International Working Group (BPV XI)

S. B. Parkash, <i>Chair</i>	N. Palm
D. Narain, <i>Vice Chair</i>	D. Rawal
K. K. Rai, <i>Secretary</i>	R. Sahai
Z. M. Mansuri	R. K. Sharma
M. R. Nadgouda	

Special Working Group on Editing and Review (BPV XI)

R. W. Swayne, <i>Chair</i>	K. R. Rao
M. Orihuela	

Task Group on Inspectability (BPV XI)

J. T. Lindberg, <i>Chair</i>	G. A. Lofthus
E. Henry, <i>Secretary</i>	S. Matsumoto
A. Cardillo	D. E. Matthews
D. R. Cordes	P. J. O'Regan
M. J. Ferlisi	J. B. Ossmann
P. Gionta	S. A. Sabo
D. O. Henry	P. Sullivan
J. Honcharik	C. Thomas
R. Klein	J. Tucker
C. Latiolais	

Task Group on ISI of Spent Nuclear Fuel Storage and Transportation Containment Systems (BPV XI)

K. Hunter, <i>Chair</i>	M. Liu
M. Orihuela, <i>Secretary</i>	K. Mauskar
D. J. Ammerman	R. M. Meyer
W. H. Borter	B. L. Montgomery
J. Broussard	R. M. Pace
S. Brown	E. L. Pleins
C. R. Bryan	M. A. Richter
T. Carraher	B. Sarno
S. Corcoran	R. Sindelar
D. Dunn	M. Staley
N. Fales	J. Wellwood
R. C. Folley	X. J. Zhai
G. Grant	P.-S. Lam, <i>Alternate</i>
B. Gutherman	G. White, <i>Alternate</i>
M. W. Joseph	J. Wise, <i>Alternate</i>
M. Keene	H. Smith, <i>Contributing Member</i>

Subgroup on Evaluation Standards (SG-ES) (BPV XI)

W. H. Bamford, <i>Chair</i>	R. O. McGill
N. A. Palm, <i>Secretary</i>	H. S. Mehta
M. Brumovsky	K. Miyazaki
H. D. Chung	R. M. Pace
R. C. Cipolla	J. C. Poehler
C. M. Faigy	S. Ranganath
M. M. Farooq	D. A. Scarth
B. R. Ganta	D. J. Shim
T. J. Griesbach	G. L. Stevens
K. Hasegawa	A. Udyawar
K. Hojo	T. V. Vo
D. N. Hopkins	G. M. Wilkowski
D. R. Lee	S. X. Xu
Y. S. Li	M. L. Benson, <i>Alternate</i>

Task Group on Evaluation of Beyond Design Basis Events (SG-ES) (BPV XI)

R. M. Pace, <i>Chair</i>	M. Hayashi
S. X. Xu, <i>Secretary</i>	K. Hojo
F. G. Abatt	S. A. Kleinsmith
G. A. Antaki	H. S. Mehta
P. R. Donavin	T. V. Vo
R. G. Gilada	G. M. Wilkowski
T. J. Griesbach	T. Weaver, <i>Contributing Member</i>

Working Group on Flaw Evaluation (SG-ES) (BPV XI)

R. C. Cipolla, <i>Chair</i>	C. Liu
S. X. Xu, <i>Secretary</i>	M. Liu
W. H. Bamford	H. S. Mehta
M. L. Benson	G. A. A. Miessi
M. Brumovsky	K. Miyazaki
H. D. Chung	S. Noronha
M. A. Erickson	R. K. Qashu
C. M. Faidy	S. Ranganath
M. M. Farooq	P. J. Rush
B. R. Ganta	D. A. Scarth
R. G. Gilada	W. L. Server
F. D. Hayes	D. J. Shim
P. H. Hoang	S. Smith
K. Hojo	M. Uddin
D. N. Hopkins	A. Udyawar
S. Kalyanam	T. V. Vo
Y. Kim	K. Wang
V. Lacroix	B. Wasiluk
D. R. Lee	G. M. Wilkowski
Y. S. Li	

Working Group on Pipe Flaw Evaluation (SG-ES) (BPV XI)

D. A. Scarth, <i>Chair</i>	S. Kalyanam
G. M. Wilkowski, <i>Secretary</i>	K. Kashima
K. Azuma	V. Lacroix
M. L. Benson	Y. S. Li
M. Brumovsky	R. O. McGill
F. W. Brust	H. S. Mehta
H. D. Chung	G. A. A. Miessi
R. C. Cipolla	K. Miyazaki
N. G. Cofie	S. H. Pellet
C. M. Faidy	P. J. Rush
M. M. Farooq	C. J. Sallaberry
B. R. Ganta	W. L. Server
S. R. Gosselin	D. J. Shim
C. E. Guzman-Leong	S. Smith
K. Hasegawa	M. F. Uddin
P. H. Hoang	A. Udyawar
K. Hojo	T. V. Vo
D. N. Hopkins	K. Wang
E. J. Houston	B. Wasiluk
R. Janowiak	S. X. Xu

Working Group on Flaw Evaluation Reference Curves (BPV XI)

G. L. Stevens, <i>Chair</i>	A. Jenks
A. Udyawar, <i>Secretary</i>	V. Lacroix
W. H. Bamford	H. S. Mehta
M. L. Benson	K. Miyazaki
F. W. Brust	B. Pellereau
R. C. Cipolla	S. Ranganath
M. M. Farooq	D. A. Scarth
A. E. Freed	D. J. Shim
P. Gill	S. Smith
K. Hasegawa	T. V. Vo
K. Hojo	S. X. Xu
R. Janowiak	

Task Group on Code Case N-513 (WG-PFE) (BPV XI)

R. O. McGill, <i>Chair</i>	S. M. Parker
E. J. Houston, <i>Secretary</i>	D. Rudland
G. A. Antaki	P. J. Rush
R. C. Cipolla	D. A. Scarth
M. M. Farooq	S. X. Xu
R. Janowiak	

Task Group on Evaluation Procedures for Degraded Buried Pipe (WG-PFE) (BPV XI)

R. O. McGill, <i>Chair</i>	M. Kassar
S. X. Xu, <i>Secretary</i>	M. Moenssens
F. G. Abatt	D. P. Munson
G. A. Antaki	R. M. Pace
R. C. Cipolla	S. H. Pellet
R. G. Gilada	D. Rudland
K. Hasegawa	P. J. Rush
K. M. Hoffman	D. A. Scarth
R. Janowiak	

Working Group on Operating Plant Criteria (SG-ES) (BPV XI)

N. A. Palm, <i>Chair</i>	H. Kobayashi
A. E. Freed, <i>Secretary</i>	H. S. Mehta
K. R. Baker	A. D. Odell
W. H. Bamford	R. M. Pace
M. Brumovsky	J. C. Poehler
M. A. Erickson	S. Ranganath
T. J. Griesbach	W. L. Server
M. Hayashi	C. A. Tomes
R. Janowiak	A. Udyawar
M. Kirk	T. V. Vo
S. A. Kleinsmith	H. Q. Xu

Task Group on Flaw Evaluation for HDPE Pipe (WG-PFE) (BPV XI)

P. J. Rush, <i>Chair</i>	D. J. Shim
P. Krishnaswamy	M. Troughton
M. Moenssens	J. Wright
D. P. Munson	S. X. Xu
D. A. Scarth	

Task Group on Appendix L (WG-OPC) (BPV XI)

N. Glunt, <i>Chair</i>	C.-S. Oh
R. M. Pace, <i>Secretary</i>	H. Park
A. E. Freed	S. Ranganath
M. A. Gray	D. J. Shim
T. J. Griesbach	S. Smith
H. Nam	G. L. Stevens
A. Nana	A. Udyawar
A. D. Odell	

Subgroup on Nondestructive Examination (SG-NDE) (BPV XI)

J. T. Lindberg, <i>Chair</i>	J. Harrison
D. R. Cordes, <i>Secretary</i>	D. O. Henry
M. Briley	G. A. Lofthus
C. Brown	S. A. Sabo
T. L. Chan	F. J. Schaaf, Jr.
T. Cinson	R. V. Swain
S. E. Cumblidge	C. A. Nove, <i>Alternate</i>
K. J. Hacker	

Working Group on Personnel Qualification and Surface Visual and Eddy Current Examination (SG-NDE) (BPV XI)

C. Brown, *Chair*
T. Cinson, *Secretary*
J. E. Aycock
J. Bennett
S. E. Cumblidge
A. Diaz
N. Farenbaugh

D. O. Henry
J. T. Lindberg
C. Shinsky
R. Tedder
T. Thulien
J. T. Timm

Working Group on Procedure Qualification and Volumetric Examination (SG-NDE) (BPV XI)

G. A. Lofthus, *Chair*
J. Harrison, *Secretary*
M. Briley
A. Bushmire
D. R. Cordes
S. R. Doctor
K. J. Hacker
W. A. Jensen

D. A. Kull
C. Latiolais
C. A. Nove
S. A. Sabo
R. V. Swain
D. Van Allen
D. K. Zimmerman
B. Lin, *Alternate*

Subgroup on Repair/Replacement Activities (SG-RRA) (BPV XI)

S. L. McCracken, *Chair*
E. V. Farrell, Jr., *Secretary*
J. F. Ball
M. Brandes
S. B. Brown
R. Clow
P. D. Fisher
M. L. Hall
W. C. Holston
J. Honcharik
A. B. Meichler

B. R. Newton
S. A. Norman
J. E. O'Sullivan
G. C. Park
R. R. Stevenson
R. W. Swayne
D. J. Tilly
D. E. Waskey
J. G. Weicks
B. Lin, *Alternate*
J. K. Loy, *Alternate*

Working Group on Welding and Special Repair Processes (SG-RRA) (BPV XI)

J. G. Weicks, *Chair*
D. Barborak
S. J. Findlan
P. D. Fisher
R. C. Folley
M. L. Hall
W. C. Holston
J. Honcharik
C. C. Kim

M. Kris
S. E. Marlette
S. L. McCracken
B. R. Newton
J. E. O'Sullivan
D. J. Tilly
D. E. Waskey
J. K. Loy, *Alternate*

Task Group on Temper Bead Welding (BPV XI)

S. J. Findlan, *Chair*
D. Barborak
M. L. Hall
S. L. McCracken
N. Mohr
B. R. Newton
G. Olson

J. E. O'Sullivan
A. Patel
J. Tatman
D. J. Tilly
D. E. Waskey
J. G. Weicks

Task Group on Weld Overlay (BPV XI)

S. L. McCracken, *Chair*
D. Barborak
S. J. Findlan
M. L. Hall
W. C. Holston
S. Hunter
C. Lohse
S. E. Marlette

B. R. Newton
G. Olson
A. Patel
P. Raynaud
D. W. Sandusky
D. E. Waskey
J. G. Weicks

Working Group on Non-Metals Repair/Replacement Activities (SG-RRA) (BPV XI)

J. E. O'Sullivan, *Chair*
S. Schuessler, *Secretary*
M. Brandes
D. R. Dechene
J. Johnston, Jr.
B. Lin

M. P. Marohl
T. M. Musto
S. Patterson
A. Pridmore
F. J. Schaaf, Jr.
R. Stakenborghs

Task Group on HDPE Piping for Low Safety Significance Systems (WG-NMRA) (BPV XI)

M. Brandes, *Chair*
J. E. O'Sullivan, *Secretary*
M. Golliet
B. Lin

T. M. Musto
F. J. Schaaf, Jr.
S. Schuessler
R. Stakenborghs

Task Group on Repair by Carbon Fiber Composites (WGN-MRR) (BPV XI)

J. E. O'Sullivan, *Chair*
S. F. Arnold
S. W. Choi
D. R. Dechene
M. Golliet
L. S. Gordon
M. Kuntz
H. Lu
M. P. Marohl
L. Nadeau
C. A. Nove

R. P. Ojdrovic
A. Pridmore
P. Raynaud
S. Rios
C. W. Rowley
J. Sealey
R. Stakenborghs
N. Stoeva
M. F. Uddin
J. Wen
B. Davenport, *Alternate*

Working Group on Design and Programs (SG-RRA) (BPV XI)

S. B. Brown, *Chair*
A. B. Meichler, *Secretary*
O. Bhatti
R. Clow
R. R. Croft
E. V. Farrell, Jr.

B. Lin
H. Malikowski
G. C. Park
M. A. Pyne
R. R. Stevenson
R. W. Swayne

Task Group on Repair and Replacement Optimization (WG-D&P) (BPV XI)

S. L. McCracken, *Chair*
T. Basso
R. Clow
K. Dietrich
E. V. Farrell, Jr.
R. C. Folley
M. L. Hall
W. C. Holston

D. Jacobs
H. Malikowski
T. Nuoffer
G. C. Park
A. Patel
R. R. Stevenson
R. G. Weicks

Subgroup on Water-Cooled Systems (SG-WCS) (BPV XI)

M. J. Ferlisi, <i>Chair</i>	S. D. Kulat
J. Nygaard, <i>Secretary</i>	D. W. Lamond
J. M. Boughman	T. Nomura
S. B. Brown	T. Nuoffer
S. T. Chesworth	M. A. Pyne
H. Q. Do	H. M. Stephens, Jr.
K. W. Hall	R. Thames
P. J. Hennessey	M. Weis
K. M. Hoffman	M. J. Homiack, <i>Alternate</i>
A. E. Keyser	

Task Group on High Strength Nickel Alloys Issues (SG-WCS) (BPV XI)

H. Malikowski, <i>Chair</i>	S. E. Marlette
K. Dietrich, <i>Secretary</i>	B. L. Montgomery
W. H. Bamford	G. C. Park
T. Cinson	W. Sims
P. R. Donavin	D. E. Waskey
K. M. Hoffman	C. Wax
H. Kobayashi	K. A. Whitney
C. Lohse	

Working Group on Containment (SG-WCS) (BPV XI)

M. J. Ferlisi, <i>Chair</i>	J. A. Munshi
R. Thames, <i>Secretary</i>	M. Sircar
P. S. Ghosal	P. C. Smith
H. T. Hill	S. Walden
A. E. Keyser	M. Weis
B. Lehman	S. G. Brown, <i>Alternate</i>
P. Leininger	

Working Group on Inspection of Systems and Components (SG-WCS) (BPV XI)

H. Q. Do, <i>Chair</i>	J. Howard
M. Weis, <i>Secretary</i>	A. Keller
R. W. Blyde	S. D. Kulat
K. Caver	E. Lantz
C. Cueto-Felgueroso	A. Maekawa
M. J. Ferlisi	T. Nomura
M. L. Garcia Heras	J. C. Nygaard
K. W. Hall	S. Orita
K. M. Hoffman	

Working Group on Pressure Testing (SG-WCS) (BPV XI)

J. M. Boughman, <i>Chair</i>	D. W. Lamond
S. A. Norman, <i>Secretary</i>	J. K. McClanahan
T. Anselmi	T. P. McClure
B. Casey	B. L. Montgomery
Y.-K. Chung	M. Moenssens
M. J. Homiack	R. A. Nettles
A. E. Keyser	C. Thomas

Working Group on Risk-Informed Activities (SG-WCS) (BPV XI)

M. A. Pyne, <i>Chair</i>	S. D. Kulat
S. T. Chesworth, <i>Secretary</i>	D. W. Lamond
G. Brouette	G. J. Navratil
C. Cueto-Felgueroso	P. J. O'Regan
R. Haessler	N. A. Palm
J. Hakii	D. Vetter
K. W. Hall	J. C. Younger
M. J. Homiack	

Working Group on General Requirements (BPV XI)

T. Nuoffer, <i>Chair</i>	A. T. Roberts III
J. Mayo, <i>Secretary</i>	S. R. Scott
J. F. Ball	D. Vetter
T. L. Chan	S. E. Woolf
P. J. Hennessey	M. T. Audrain, <i>Alternate</i>
K. A. Kavanagh	R. S. Spencer, <i>Alternate</i>
T. N. Rezk	

Subgroup on Reliability and Integrity Management Program (SG-RIM) (BPV XI)

A. T. Roberts III, <i>Chair</i>	P. J. Hennessey
D. Vetter, <i>Secretary</i>	D. M. Jones
T. Anselmi	D. R. Lee
N. Broom	T. Lupold
V. Chugh	M. Orihuela
S. R. Doctor	F. J. Schaaf, Jr.
J. D. Fletcher	H. M. Stephens, Jr.
J. T. Fong	R. W. Swayne
J. Grimm	S. Takaya
K. Harris	R. Vayda

Working Group on MANDE (BPV XI)

H. M. Stephens, Jr., <i>Chair</i>	J. T. Fong
S. R. Doctor, <i>Vice Chair</i>	D. O. Henry
M. Turnbow, <i>Secretary</i>	T. Lupold
T. Anselmi	L. E. Mullins
N. A. Finney	M. Orihuela

JSME/ASME Joint Task Group for System-Based Code (SWG-RIM) (BPV XI)

S. Takaya, <i>Chair</i>	D. R. Lee
T. Asayama	H. Machida
S. R. Doctor	T. Muraki
K. Dozaki	A. T. Roberts III
J. T. Fong	F. J. Schaaf, Jr.
J. Hakii	R. Vayda
K. Harris	D. Watanabe
M. Hayashi	M. Morishita, <i>Contributing Member</i>
Y. Kamishima	

COMMITTEE ON TRANSPORT TANKS (BPV XII)

N. J. Paulick, <i>Chair</i>	T. A. Rogers
M. D. Rana, <i>Vice Chair</i>	R. C. Sallash
J. Oh, <i>Staff Secretary</i>	M. Shah
A. N. Antoniou	S. Staniszewski
P. Chilukuri	A. P. Varghese
W. L. Garfield	Y. Doron, <i>Contributing Member</i>
M. Pitts	R. Meyers, <i>Contributing Member</i>
J. Roberts	M. R. Ward, <i>Contributing Member</i>

Executive Committee (BPV XII)

M. D. Rana, <i>Chair</i>	T. A. Rogers
N. J. Paulick, <i>Vice Chair</i>	R. C. Sallash
J. Oh, <i>Staff Secretary</i>	S. Staniszewski
M. Pitts	A. P. Varghese

Subgroup on Design and Materials (BPV XII)

R. C. Sallash, *Chair*
 D. K. Chandiramani
 P. Chilukuri
 Y. Doron
 S. L. McWilliams
 N. J. Paulick
 M. D. Rana
 T. A. Rogers
 M. Shah
 S. Staniszewski

A. P. Varghese
 K. Xu
 A. T. Duggleby, *Contributing Member*
 R. D. Hayworth, *Contributing Member*
 G. G. Karcher, *Contributing Member*
 B. E. Spencer, *Contributing Member*
 M. R. Ward, *Contributing Member*
 J. Zheng, *Contributing Member*

Subgroup on Fabrication, Inspection, and Continued Service (BPV XII)

M. Pitts, *Chair*
 P. Chilukuri
 Y. Doron
 M. Koprivnak
 P. Miller
 O. Mulet
 J. Roberts

T. A. Rogers
 R. C. Sallash
 L. Selensky
 S. Staniszewski
 R. D. Hayworth
 G. McRae, *Contributing Member*

Subgroup on General Requirements (BPV XII)

S. Staniszewski, *Chair*
 B. F. Pittel, *Secretary*
 A. N. Antoniou
 Y. Doron
 H. Ebben III
 J. L. Freiler
 W. L. Garfield
 O. Mulet
 M. Pitts

R. C. Sallash
 L. Selensky
 P. Chilukuri, *Contributing Member*
 T. J. Hitchcock, *Contributing Member*
 S. L. McWilliams, *Contributing Member*
 T. A. Rogers, *Contributing Member*
 D. G. Shelton, *Contributing Member*
 M. R. Ward, *Contributing Member*

Subgroup on Nonmandatory Appendices (BPV XII)

T. A. Rogers, *Chair*
 S. Staniszewski, *Secretary*
 P. Chilukuri
 N. J. Paulick

M. Pitts
 R. C. Sallash
 D. G. Shelton
 Y. Doron, *Contributing Member*

COMMITTEE ON OVERPRESSURE PROTECTION (BPV XIII)

D. B. DeMichael, *Chair*
 D. Miller, *Vice Chair*
 C. E. O'Brien, *Staff Secretary*
 J. F. Ball
 J. Burgess
 B. Calderon
 J. W. Dickson
 A. Donaldson
 S. F. Harrison, Jr.
 B. K. Nutter
 T. Patel
 M. Poehlmann
 T. R. Tarbay
 D. E. Tompkins
 Z. Wang
 J. A. West
 A. Wilson
 H. Aguilar, *Contributing Member*

R. W. Barnes, *Contributing Member*
 R. D. Danzy, *Contributing Member*
 M. Elias, *Contributing Member*
 D. Felix, *Contributing Member*
 A. Frigerio, *Contributing Member*
 J. P. Glaspie, *Contributing Member*
 A. Hassan, *Contributing Member*
 P. K. Lam, *Contributing Member*
 J. M. Levy, *Contributing Member*
 M. Mengon, *Contributing Member*
 J. Mize, *Contributing Member*
 M. Mullavey, *Contributing Member*
 S. K. Parimi, *Contributing Member*
 R. Raman, *Contributing Member*
 M. Reddy, *Contributing Member*
 S. Ruesenberg, *Contributing Member*
 K. Shores, *Contributing Member*
 D. E. Tezzo, *Contributing Member*

Executive Committee (BPV XIII)

D. Miller, *Chair*
 D. B. DeMichael, *Vice Chair*
 C. E. O'Brien, *Staff Secretary*
 J. F. Ball

A. Donaldson
 B. K. Nutter
 J. A. West

Subgroup on Design and Materials (BPV XIII)

D. Miller, *Chair*
 T. Patel, *Vice Chair*
 B. Mruk, *Secretary*
 C. E. Bear
 A. Biesecker
 W. E. Chapin
 J. L. Freiler
 B. Joergensen
 V. Kalyanasundaram
 B. J. Mollitor
 A. Swearingin

T. R. Tarbay
 J. A. West
 A. Williams
 D. J. Azukas, *Contributing Member*
 R. D. Danzy, *Contributing Member*
 A. Hassan, *Contributing Member*
 R. Miyata, *Contributing Member*
 M. Mullavey, *Contributing Member*
 S. K. Parimi, *Contributing Member*
 G. Ramirez, *Contributing Member*
 K. Shores, *Contributing Member*

Subgroup on General Requirements (BPV XIII)

A. Donaldson, *Chair*
 B. F. Pittel, *Vice Chair*
 J. M. Levy, *Secretary*
 D. J. Azukas
 J. F. Ball
 M. Z. Brown
 J. Burgess
 D. B. DeMichael
 M. Elias
 S. T. French
 J. Gillham
 R. Klimas, Jr.
 Z. E. Kumana
 P. K. Lam
 K. R. May
 J. Mize
 L. Moedinger
 M. Mullavey
 M. Poehlmann
 K. Shores
 D. E. Tezzo
 D. E. Tompkins
 J. F. White

B. Calderon, *Contributing Member*
 P. Chavdarov, *Contributing Member*
 T. M. Fabiani, *Contributing Member*
 J. L. Freiler, *Contributing Member*
 J. P. Glaspie, *Contributing Member*
 G. D. Goodson, *Contributing Member*
 C. Haldiman, *Contributing Member*
 J. Horne, *Contributing Member*
 B. Joergensen, *Contributing Member*
 C. Lasarte, *Contributing Member*
 D. Mainiero-Cessna, *Contributing Member*
 M. Mengon, *Contributing Member*
 D. E. Miller, *Contributing Member*
 R. Miyata, *Contributing Member*
 B. Mruk, *Contributing Member*
 R. Raman, *Contributing Member*
 M. Reddy, *Contributing Member*
 S. Ruesenberg, *Contributing Member*
 R. Sadowski, *Contributing Member*
 A. Swearingin, *Contributing Member*
 A. P. Varghese, *Contributing Member*

Subgroup on Nuclear (BPV XIII)

J. F. Ball, *Chair*
 K. R. May, *Vice Chair*
 R. Krithivasan, *Secretary*
 J. W. Dickson
 S. Jones
 R. Lack
 D. Miller
 T. Patel

K. Shores
 I. H. Tseng
 J. Yu
 N. J. Hansing, *Alternate*
 J. M. Levy, *Alternate*
 B. J. Yonsky, *Alternate*
 S. T. French, *Contributing Member*
 D. B. Ross, *Contributing Member*

Subgroup on Testing (BPV XIII)

B. K. Nutter, <i>Chair</i>	A. Strecker
T. P. Beirne, <i>Vice Chair</i>	J. R. Thomas, Jr.
J. W. Dickson, <i>Secretary</i>	Z. Wang
B. Calderon	A. Wilson
V. Chicola III	D. Nelson, <i>Alternate</i>
B. Engman	J. Cockerham, <i>Contributing Member</i>
R. J. Garnett	J. Mize, <i>Contributing Member</i>
R. Houk	M. Mullavey, <i>Contributing Member</i>
R. Lack	R. Raman, <i>Contributing Member</i>
M. Mengon	S. Ruesenberg, <i>Contributing Member</i>
C. Sharpe	K. Shores, <i>Contributing Member</i>

US TAG to ISO TC 185 Safety Devices for Protection Against Excessive Pressure (BPV XIII)

D. Miller, <i>Chair</i>	B. K. Nutter
C. E. O'Brien, <i>Staff Secretary</i>	T. Patel
J. F. Ball	J. R. Thomas, Jr.
T. J. Bevilacqua	J. A. West
D. B. DeMichael	J. F. White
J. W. Dickson	

COMMITTEE ON BOILER AND PRESSURE VESSEL CONFORMITY ASSESSMENT (CBPVCA)

R. V. Wielgoszinski, <i>Chair</i>	T. P. Beirne, <i>Alternate</i>
G. Scribner, <i>Vice Chair</i>	M. Blankinship, <i>Alternate</i>
P. Murray, <i>Staff Secretary</i>	J. W. Dickson, <i>Alternate</i>
J. P. Chicoine	J. M. Downs, <i>Alternate</i>
P. D. Edwards	B. J. Hackett, <i>Alternate</i>
T. E. Hansen	W. Hibdon, <i>Alternate</i>
B. L. Krasium	Y.-S. Kim, <i>Alternate</i>
P. F. Martin	B. Morelock, <i>Alternate</i>
L. E. McDonald	M. Poehlmann, <i>Alternate</i>
D. Miller	R. Rockwood, <i>Alternate</i>
I. Powell	B. C. Turczynski, <i>Alternate</i>
L. Skarin	D. E. Tuttle, <i>Alternate</i>
R. Uebel	S. V. Voorhees, <i>Alternate</i>
E. A. Whittle	D. Cheetham, <i>Contributing Member</i>
P. Williams	A. J. Spencer, <i>Honorary Member</i>

COMMITTEE ON NUCLEAR CERTIFICATION (CNC)

R. R. Stevenson, <i>Chair</i>	E. A. Whittle
J. DeKleine, <i>Vice Chair</i>	T. Aldo, <i>Alternate</i>
Z. McLucas, <i>Staff Secretary</i>	M. Blankinship, <i>Alternate</i>
J. F. Ball	P. J. Coco, <i>Alternate</i>
G. Claffey	N. DeSantis, <i>Alternate</i>
G. Gobbi	C. Dinic, <i>Alternate</i>
S. M. Goodwin	P. D. Edwards, <i>Alternate</i>
J. W. Highlands	T. B. Franchuk, <i>Alternate</i>
K. A. Kavanagh	K. M. Hottle, <i>Alternate</i>
J. C. Krane	P. Krane, <i>Alternate</i>
M. A. Lockwood	D. Nenstiel, <i>Alternate</i>
T. McGee	L. Ponce, <i>Alternate</i>
E. L. Pleins	P. F. Prescott, <i>Alternate</i>
T. E. Quaka	S. V. Voorhees, <i>Alternate</i>
T. N. Rezk	M. Wilson, <i>Alternate</i>
G. E. Szabatura	S. Yang, <i>Alternate</i>
C. Turylo	S. F. Harrison, Jr., <i>Contributing Member</i>
D. M. Vickery	

SUMMARY OF CHANGES

Errata to the BPV Code may be posted on the ASME website to provide corrections to incorrectly published items, or to correct typographical or grammatical errors in the BPV Code. Such Errata shall be used on the date posted.

Information regarding Special Notices and Errata is published by ASME at <http://go.asme.org/BPVCerrata>.

Changes given below are identified on the pages by a margin note, **(21)**, placed next to the affected area.

<i>Page</i>	<i>Location</i>	<i>Change</i>
vi	List of Sections	(1) Listing for Section III updated (2) Section XIII added (3) Code Case information updated
viii	Foreword	(1) Subparagraph (k) added and subsequent subparagraph redesignated (2) Second footnote revised (3) Last paragraph added
xi	Submittal of Technical Inquiries to the Boiler and Pressure Vessel Standards Committees	Paragraphs 1(a)(3)(-b), 2(b), and 5(a)(3) revised
xiv	Personnel	Updated
2	Article 2	Definition of <i>water temperature, maximum</i> added

LIST OF CHANGES IN RECORD NUMBER ORDER

DELETED

CROSS-REFERENCING AND STYLISTIC CHANGES IN THE BOILER AND PRESSURE VESSEL CODE

There have been structural and stylistic changes to BPVC, starting with the 2011 Addenda, that should be noted to aid navigating the contents. The following is an overview of the changes:

Subparagraph Breakdowns/Nested Lists Hierarchy

- First-level breakdowns are designated as (a), (b), (c), etc., as in the past.
- Second-level breakdowns are designated as (1), (2), (3), etc., as in the past.
- Third-level breakdowns are now designated as (-a), (-b), (-c), etc.
- Fourth-level breakdowns are now designated as (-1), (-2), (-3), etc.
- Fifth-level breakdowns are now designated as (+a), (+b), (+c), etc.
- Sixth-level breakdowns are now designated as (+1), (+2), etc.

Footnotes

With the exception of those included in the front matter (roman-numbered pages), all footnotes are treated as endnotes. The endnotes are referenced in numeric order and appear at the end of each BPVC section/subsection.

Submittal of Technical Inquiries to the Boiler and Pressure Vessel Standards Committees

Submittal of Technical Inquiries to the Boiler and Pressure Vessel Standards Committees has been moved to the front matter. This information now appears in all Boiler Code Sections (except for Code Case books).

Cross-References

It is our intention to establish cross-reference link functionality in the current edition and moving forward. To facilitate this, cross-reference style has changed. Cross-references within a subsection or subarticle will not include the designator/identifier of that subsection/subarticle. Examples follow:

- *(Sub-)Paragraph Cross-References.* The cross-references to subparagraph breakdowns will follow the hierarchy of the designators under which the breakdown appears.
 - If subparagraph (-a) appears in X.1(c)(1) and is referenced in X.1(c)(1), it will be referenced as (-a).
 - If subparagraph (-a) appears in X.1(c)(1) but is referenced in X.1(c)(2), it will be referenced as (1)(-a).
 - If subparagraph (-a) appears in X.1(c)(1) but is referenced in X.1(e)(1), it will be referenced as (c)(1)(-a).
 - If subparagraph (-a) appears in X.1(c)(1) but is referenced in X.2(c)(2), it will be referenced as X.1(c)(1)(-a).
- *Equation Cross-References.* The cross-references to equations will follow the same logic. For example, if eq. (1) appears in X.1(a)(1) but is referenced in X.1(b), it will be referenced as eq. (a)(1)(1). If eq. (1) appears in X.1(a)(1) but is referenced in a different subsection/subarticle/paragraph, it will be referenced as eq. X.1(a)(1)(1).

INTENTIONALLY LEFT BLANK

ARTICLE 1

INTRODUCTION

The purpose of these recommended guidelines is to promote safety in the use of steam heating, hot water heating, and hot water supply boilers that are directly fired with oil, gas, electricity, coal, or other solid and liquid fuels. These guidelines are intended for use by those directly responsible for operating and maintaining heating and hot water supply boilers. These guidelines apply only to boilers subject to the service restrictions of Section IV, HG-101 of the ASME Boiler and Pressure Vessel Code, as follows:

(a) steam boilers for operation at pressures not exceeding 15 psi (100 kPa)

(b) hot water heating and hot water supply boilers for operation at pressures not exceeding 160 psi (1 100 kPa) and/or temperatures not exceeding 250°F (120°C)

These guidelines apply to the boiler proper and to pipe connections up to and including the valve or valves as required by the Code. Guidelines are also provided for operation of auxiliary equipment and appliances that affect the safe and reliable operation of heating boilers.

The use of the word “shall” in these Guidelines reflects the mandatory nature of the Section IV requirements. The reader should consult the latest edition of Section IV for the current requirements.

Formulating a set of guidelines that is applicable to all sites and types of installations is difficult; therefore, it may be advisable to depart from these guidelines in specific cases. Manufacturer’s operating instructions should always be adhered to, as should any local jurisdictional requirements. Other industry-accepted codes and standards, such as the National Fire Protection Association’s (NFPA) codes covering prevention of furnace explosions, are recommended for additional guidance.

These guidelines are not intended to be used in lieu of any required inspections and operations mandated by jurisdictions, the National Board Inspection Code, or insurance companies.

ARTICLE 2

GLOSSARY

(21)

acid: any chemical compound with a pH less than 7 containing hydrogen that dissociates to produce hydrogen ions when dissolved in water and is capable of neutralizing hydroxides or bases to produce salts.

acidity: the state of being acid; the degree or quantity of acid present.

air: a mixture of oxygen, nitrogen, and other gases that, with varying amounts of water vapor, form the atmosphere of the earth.

air-fuel mixture: the ratio of the weight of air to the weight of fuel in a mixture of air and fuel.

air moisture: the water vapor suspended in the air.

alkali: any chemical compound of a basic nature that dissociates to produce hydroxyl ions when dissolved in water and is capable of neutralizing acids to produce salts.

alkalinity: the state of being alkaline; the degree or quantity of alkali present in a solution, often expressed in terms of pH. In water analysis, it represents the carbonates, bicarbonates, hydroxides, and occasionally the borates, silicates, and phosphates present as determined by titration with a standard acid and generally expressed as calcium carbonate in parts per million.

atmospheric pressure: the barometric reading of pressure exerted by the atmosphere, which at sea level is 14.7 psi (101 kPa) or 29.9 in. Hg (101 kPa).

Authorized Inspection Agency (Inservice): either

(a) a jurisdictional authority as defined in the National Board Constitution, or

(b) an entity that is accredited by the National Board as satisfying the requirements of NB-369, Qualifications and Duties for Authorized Inspection Agencies (AIA) Performing Inservice Inspection Activities; NB-371, Accreditation of Owner-User Inspection Organizations (OUIO); or NB-390, Qualifications and Duties for Federal Inspection Agencies (FIA) Performing Inservice Inspection Activities

Authorized Inspection Agency (New Construction): an organization that is accredited by ASME in accordance with ASME QAI-1, Qualifications for Authorized Inspection, and meets the requirements of the National Board of Boiler and Pressure Vessel Inspectors.

Authorized Inspector: an Inspector who holds a valid National Board New Construction Commission with the appropriate endorsement and who is designated as such by an Authorized Inspection Agency.

baffle: a plate or wall for deflecting gases or liquids.

barometric pressure: atmospheric pressure as measured by a barometer, usually expressed in inches (millimeters) of mercury.

blowdown: a process for removing unwanted solid particulates and sludge from the boiler water. This process can be either manual or continuous. Valves are opened to use the boiler pressure to blow the particulates out of the boiler.

blower: a fan used to move air under pressure.

blowoff: a pipe connection provided with valves through which the water in the boiler may be blown out under pressure.

boiler: a fired pressure vessel in which water or some other fluid is heated or steam is generated.

boiler, firetube: a boiler with tubes that are surrounded by water and steam and through which the products of combustion pass.

boiler, hot water heating: a boiler designed to heat water for circulation through an external space-heating system.

boiler, hot water supply: a boiler used to heat water for purposes other than space heating.

boiler, watertube: a boiler in which the tubes contain water and steam with the heat being applied to the outside surface.

boiler layup: any extended period of time during which the boiler is not expected to operate and suitable precautions are made to protect it against corrosion, scaling, pitting, etc., on the water and fire sides.

breeching: a duct for the transport of the products of combustion between the boiler and the stack.

buckstay: a structural member placed against a furnace or boiler wall to restrain the motion of the wall.

burner: a device for the introduction of fuel and air into the combustion zone at the desired velocities, turbulence, and concentration to establish and maintain proper ignition and combustion of the fuel.

carbon: the element that is the principal combustible constituent of all fuels.

coal: solid hydrocarbon fuel formed by ancient decomposition of woody substance under conditions of heat and pressure.

coke: fuel consisting largely of the fixed carbon and ash in coal obtained by the destructive distillation of bituminous coal.

colloid: a substance microscopically dispersed throughout another substance but incapable of passing through a semipermeable membrane.

combustion: the rapid chemical reaction of oxygen with the combustible elements of a fuel resulting in the production of heat.

complete combustion: the complete oxidation of all the combustible constituents of a fuel.

condensate: water formed as a result of a phase change from gas to liquid.

control: a device designed to regulate the fuel, exhaust, air, water, or electrical supplies to a powered device. It may be manual, semiautomatic, or automatic.

convection: the transmission of heat by the circulation of a liquid or a gas. It may be natural or forced.

damper loss: the reduction in the static pressure of a gas flowing across a damper.

delayed combustion: continuation of combustion beyond the furnace.

differential temperature: the temperature differential between two spaces; for example, the difference in temperature between the inlet and outlet of the boiler.

distillation: vaporization of a substance with subsequent recovery of the vapor by condensation.

draft: a pressure difference that causes gases or air to flow through a chimney, vent, or boiler; also, a measurement of negative pressure in a vent used to indicate potential for flue gas flow.

drain: a valved connection at a low point for the removal of water.

drum: a cylindrical shell closed at both ends and designed to withstand internal pressure.

duct: an enclosed passage for air or gas flow.

electric ignition: ignition of a pilot or main flame by the use of an electric arc or glow plug.

excess air: air supplied for combustion in excess of that theoretically required for complete combustion.

expander: a tool used to create a permanent seal between a tube and a tubesheet or header by expanding the tube so it is compressed against the other surface.

extended surface: metallic heat-absorbing surface protruding beyond the tube wall.

fan: a machine consisting of a rotor and housing for moving air or gases.

fan, forced-draft: a type of pressurized fan producing a positive pressure within a system or equipment.

fan, induced-draft: a fan exhausting hot gases from heat-absorbing equipment.

feed pipe: a pipe through which water is conducted into a boiler.

fin: a projection from a surface subject to heat.

fin tube: a tube with one or more fins.

firetube: a tube in a boiler having water on the outside and carrying the products of combustion on the inside.

fixed carbon: the solid combustible residue remaining after coal, coke, or bituminous materials are heated and the volatile matter expelled. The fixed carbon content is determined by subtracting from 100% the percentages of moisture, volatile matter, and ash in a sample.

flame: a luminous body of burning gas or vapor.

flash point: the lowest temperature at which a volatile material can vaporize to form a combustible mixture in air.

float switch: a float-operated switch that makes and breaks an electric circuit in accordance with a change in a predetermined water level.

flow switch: a device that monitors the flow of air, steam, or liquid.

flue: a passage for products of combustion.

flue gas: the gaseous products of combustion.

furnace: the part of a boiler in which combustion of fuel takes place or in which primary furnace gases are conveyed.

gauge cock: a valve used to isolate a boiler from a measuring device such as a pressure gauge or gauge glass.

gauge glass: the transparent part of a water gauge assembly connected directly or through a water column to the boiler to indicate the water level in the boiler.

gauge pressure: the pressure above atmospheric pressure.

gas analysis: the determination of the percentages of various constituents of a gaseous mixture.

grate: the surface on which fuel is supported and burned, and through which air is passed for combustion.

grate bars: those parts of the fuel-supporting surface arranged to admit air for combustion.

handhole: an opening in a pressure part for access, too small for a person to enter.

header: piping that connects two or more boilers together.

heat balance: an accounting of the distribution from one medium to another.

heating surface: the surface that is exposed to the heating medium for absorption and transfer of heat to the heated medium as determined according to Section IV, HG-403.

hydrocarbon: a chemical compound of hydrogen and carbon.

hydrostatic test: a strength and water-tightness test of a closed pressure vessel by water pressure.

impingement: the striking of moving matter, such as the flow of steam, water, gas, or solids, against another surface.

inhibitor: a compound that slows down or stops an undesired chemical reaction such as corrosion or oxidation.

insulation: a material of low thermal conductivity used to reduce heat losses.

integral blower: a blower built as an integral part of a device to supply air thereto.

intermittent firing: a method of firing by which fuel and air are introduced into and burned in a furnace for a short period, after which the flow is stopped. The cycle is then repeated.

jurisdiction: a governmental entity with the power, right, or authority to interpret and enforce law, rules, or ordinances pertaining to boilers, pressure vessels, or other retaining items; it includes National Board member jurisdictions, defined as "jurisdictional authorities."

jurisdictional authority: a member of the National Board, as defined in the National Board Constitution.

lagging: a covering, usually of insulating material, on pipe or ducts.

load: the system demand for output of steam or hot water, in pounds (kilograms) per hour or British thermal units per hour (watts).

low-water fuel cutoff: a device that shuts down the fuel supply when the water level in the boiler drops below its safe operating level (the safe operating level is determined by the boiler Manufacturer).

makeup water: water introduced into the boiler to replace that lost or removed from the system.

manhole: the opening in a pressure vessel of sufficient size to permit a person to enter.

manifold: a pipe or header for collecting a fluid from, or distributing a fluid to, a number of pipes or tubes.

maximum allowable working pressure (MAWP): the maximum gauge pressure determined by employing the allowable stress values and design rules provided in Section IV.

mechanical draft: a differential pressure created by mechanical means.

modulation of burner: varying the burner firing rate to match the load demand.

neutralize: to counteract acidity with an alkali or alkalinity with an acid.

National Board: the National Board of Boiler and Pressure Vessel Inspectors.

National Board Commissioned Inspector: an individual who holds a valid and current National Board Commission.

operating pressure: the actual gauge pressure at the boiler outlet.

operating temperature: the actual temperature at the boiler outlet.

oxidation: the interaction between oxygen molecules and other substances.

packaged boiler: a boiler equipped and shipped complete with fuel-burning equipment, mechanical draft equipment, automatic controls, and accessories.

parts per million (ppm): the number of parts of a diluent in one million parts of the sample examined, which is typically air or water. In water, 1 mg/L is equivalent to 1 ppm.

pass: a confined passageway, containing heating surface, through which a gas flows in essentially one direction.

pH: a scale used to measure the degree of acidity or alkalinity of a solution. Solutions with a pH less than 7 are said to be acidic, and those with a pH greater than 7 are said to be alkaline. Water is very close to a pH of 7.

pilot flame: the flame, usually fueled by gas or light oil, that ignites the main flame.

pneumatic control: any control that uses compressed air as the actuating means.

polyphosphate: a form of phosphate that sequesters rather than precipitates hard water salts.

pour point: the temperature at which fluid begins to flow.

precipitation: the formation and settling out of solid particles in a solution.

pressure drop: the difference in pressure between two points.

pressure relief valve: a device designed to relieve pressure when the set pressure is reached.

pressure vessel: a closed vessel or container designed to confine a fluid at a pressure above atmospheric pressure.

primary air: air introduced with the fuel at the burners.

receiver: the tank portion of a condensate or vacuum return pump where condensate accumulates.

relay: an electrical device that opens or closes a circuit as its internal coil is energized or de-energized.

safety relief valve: an automatic pressure-relieving device actuated by the static pressure upstream of the valve and characterized by rapid opening or pop action, or by

opening in proportion to the increase in pressure over the set pressure, depending on application.

safety valve: an automatic pressure-relieving device actuated by the static pressure upstream of the valve and characterized by full-opening pop action. It is used for gas or vapor service.

saturated air: air that contains the maximum amount of water vapor that it can hold at its temperature and pressure.

seal weld: a weld used primarily to prevent leakage.

seam: the joint between two plates joined together.

secondary air: air for combustion supplied to the furnace to supplement the primary air.

setting: the construction surrounding the boiler and/or the tubes consisting of refractory, insulation, casing, lagging, or some combination of these.

smoke boxes: a chamber in a boiler where the smoke, etc., from the furnace is collected before going out at the chimney.

spontaneous combustion: ignition of combustible material without apparent cause.

stay: a tensile stress member to hold material or other members rigidly in position.

steam gauge: a gauge for indicating the pressure of steam.

stoichiometric combustion: the complete oxidation of all the combustible constituents of a fuel at zero excess air.

stop valve: a valve that is used to isolate a boiler from the other parts of the system.

stud: a projecting pin serving as a support or means of attachment.

thermal efficiency: the ratio of the heat absorbed by the water and steam in a boiler to the available heat in the fuel fired, expressed as a percent.

titration: a method for determining volumetrically the concentration of a desired substance in solution by adding a standard solution of known volume and strength

until the chemical reaction is completed as shown by a change in color of suitable indicator.

total air: the total quantity of air supplied to the fuel and products of combustion.

trap: a device installed in piping that is designed to prohibit the passage of steam but allow the passage of condensate and gases.

tube hole: a hole in a drum, header, or tubesheet to accommodate a tube.

tubesheet: a plate containing the tube holes.

vent: an opening in a vessel or other enclosed space for the removal of gas or other vapors.

viscosity: the measure of a fluid's resistance to flow.

water column: a vertical tubular member connected at its top and bottom to the steam and water space, respectively, of a boiler, to which the water gauge, gauge cocks, and high- and low-water-level alarms may be connected.

water gauge: the gauge glass and its fittings for attachment.

water heater: a vessel in which potable water is heated by the combustion of fuel, by electricity, or by any other source, and withdrawn for external use.

water heater, lined: a water heater with a corrosion-resistant lining designed to heat potable water.

water heater, unlined: a water heater made from corrosion-resistant materials designed to heat potable water.

water level: the elevation of the surface of the water in a boiler.

water temperature, maximum: the maximum water temperature permissible in a completed boiler or water heater.

zeolite: originally a group of natural minerals capable of removing calcium and magnesium ions from water and replacing them with sodium. The term has been broadened to include synthetic resins that similarly soften water by ion exchange.

ARTICLE 3 TYPES OF BOILERS

3.1 CLASSIFICATION

Section VI classifies heating boilers by the ASME Certification, method of manufacture, category, method of heat input, and other design characteristics.

3.2 ASME CERTIFICATION MARK

Section IV provides requirements for using the Certification Mark with H or HLW designator.

3.2.1 Boilers Stamped With the Certification Mark With H Designator

Boilers stamped with the Certification Mark with H designator may be steam heating boilers, hot water heating boilers, or hot water supply boilers.

3.2.1.1 Steam heating boilers may be used in open or closed systems in accordance with Manufacturer's instructions and jurisdictional requirements and shall operate at 15 psi (100 kPa) or less.

3.2.1.2 Hot water heating boilers are intended for use in closed-loop systems with limited potential for corrosion of the boiler. Hot water heating boilers are limited to operation at 160 psi (1 100 kPa) or less and water temperatures not exceeding 250°F (120°C) at or near the boiler outlet.

3.2.1.3 Hot water supply boilers may be used for purposes other than space heating. They may be installed in open- or closed-loop systems. Hot water supply boilers are limited to operation at 160 psi (1 100 kPa) or less and water temperatures not exceeding 250°F (120°C) at or near the boiler outlet.

3.2.2 Potable Water Heaters Stamped With the Certification Mark With H or HLW Designator

Potable water heaters stamped with the Certification Mark with H or HLW designator may be used in open-loop systems and shall be constructed from corrosion-resistant materials or with a corrosion-resistant lining. Water heaters are limited to operation at 160 psi (1 100 kPa) or less and water temperatures not exceeding 210°F (99°C) at or near the water outlet.

3.3 METHOD OF MANUFACTURE

3.3.1 Fabricated Boilers

Fabricated boilers may be steel, stainless steel, copper, and less commonly, other metals or alloys. Some boilers use polymer or composite materials in the boiler pressure vessel and are generally classified as fabricated boilers within Section VI.

3.3.1.1 Firetube Boilers. In firetube boilers, the gases of combustion pass through the tubes and the water circulates around them.

3.3.1.1.1 Horizontal Return Tube (HRT). In an HRT, the boiler is often in a refractory or brick setting and the products of combustion flow under the boiler and return through the firetubes. The furnace may also be constructed of steel. See [Figure 3.3.1.1.1-1](#).

3.3.1.1.2 Scotch-Type Boilers. The scotch boilers used in modern heating systems are similar to those originally designed for shipboard installation and are sometimes called scotch marine boilers. The furnace is a cylinder completely surrounded by water. Most scotch boilers are of the dry-back or partial wet-back design and are arranged for multiple gas passes. See [Figure 3.3.1.1.2-1](#).

3.3.1.1.3 Firebox Boilers. Firebox boilers have the firebox integral with the boiler, such as in the oil field or locomotive type, and may be single or multiple pass. The furnace of this type of boiler is usually enclosed in a water-cooled upper sheet, called a crown sheet. Various tube and shell configurations, characterizing different Manufacturers' designs, complete the boilers. See [Figures 3.3.1.1.3-1](#) and [3.3.1.1.3-2](#).

3.3.1.1.4 Vertical Firetube Boilers. In vertical firetube boilers, the products of combustion pass up or down through the tubes that are surrounded by water. See [Figure 3.3.1.1.4-1](#).

3.3.1.2 Watertube Boilers

3.3.1.2.1 In watertube boilers, the water passes through the tube and the combustion gases pass around them. Refer to the Manufacturer's instructions for minimum water flow rate requirements.

3.3.1.2.2 Watertube boilers are made in a variety of configurations with respect to tube and drum arrangement. Tubes are made from a variety of materials, including steel, stainless steel, copper, and copper fin tube.

(a) *Tray-Type Boilers.* Tray-type boilers typically have a cast manifold that distributes water flow through a bank of straight tubes. Most of these boilers are constructed of finned tubes.

(b) *Coil-Type Boilers.* Coil-type boilers may be fabricated from a single tube or multiple tubes wrapped into a cylinder or any other coiled shape.

(c) *Bent-Tube Boilers.* Bent-tube boilers are typically constructed with multiple steel tubes connected to manifolds.

3.3.2 Cast Boilers

3.3.2.1 Cast boilers are most commonly iron but may be constructed of aluminum or other metals. Cast boilers are made in two general types: sectional and one-piece (monoblock). The sections of a sectional boiler can be stacked either vertically or horizontally and are held together with tie rods, with the waterways sealed by push nipples or elastomer seals, and in rare cases, screwed nipples. See [Figures 3.3.2.1-1](#) and [3.3.2.1-2](#).

3.3.2.2 Manufacturer's instructions should be followed when adjusting nipples or tie rods. Either inadequate or excess tension on tie rods may be detrimental to the boiler.

3.3.3 Vacuum Boilers

Vacuum boilers are factory-sealed steam boilers that are operated below atmospheric pressure.

3.4 CATEGORY

Boiler category is determined according to ANSI Z21.13/CSA 4.9 and relates to the potential for condensation of the products of combustion in the venting and heat exchanger and the potential for positive pressure in the venting. Venting is discussed in [Article 5](#).

3.4.1 Noncondensing Boilers

Noncondensing boilers are Category I or Category III boilers. These boilers do not require any special construction or provisions for condensate.

3.4.2 Condensing Boilers

3.4.2.1 Condensing boilers can be constructed in a variety of designs but typically have the vent connection near the bottom of the boiler and include a drain for condensate. Condensing boilers are high-efficiency boilers that may cool the products of combustion below the dew point, resulting in condensation inside the heat exchanger and vent stack. The condensate that forms is corrosive and requires corrosion-resistant venting and neutralization of condensate.

3.4.2.2 Condensing boilers may also be referred to as Category II or Category IV boilers. A boiler categorized as a condensing boiler is not necessarily designed for condensing operation. Consult the Manufacturer's installation and operation instructions for optimal operating conditions for the boiler.

Figure 3.3.1.1.1-1 Horizontal Tube, Brick-Set

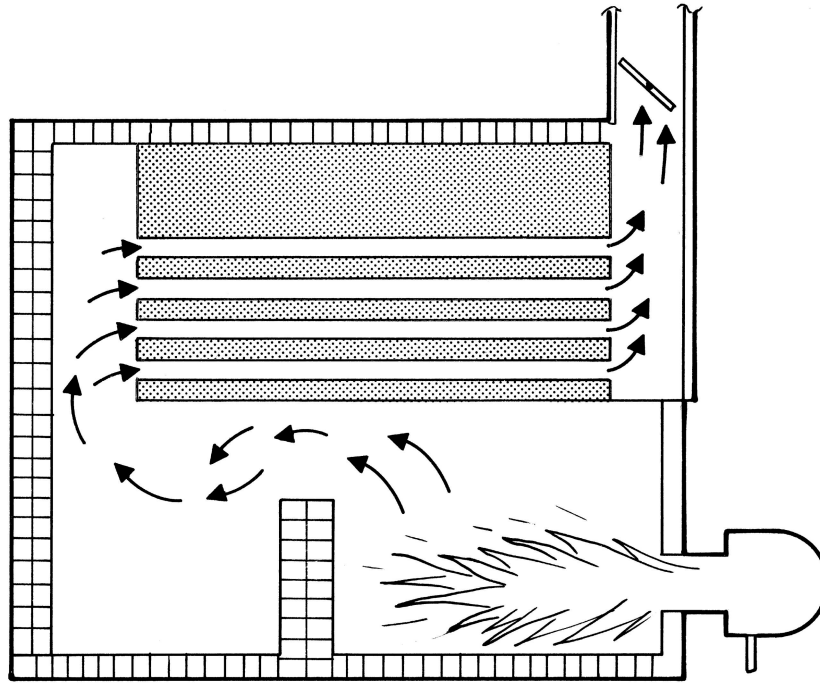

Figure 3.3.1.1.2-1 Gas Flow Patterns of Scotch-Type Boilers

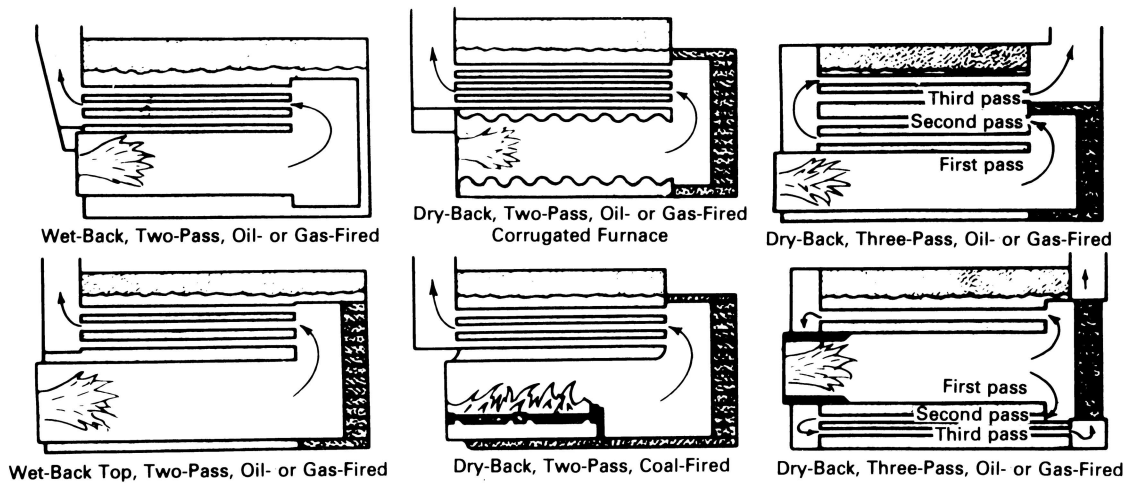

Figure 3.3.1.1.3-1 Type C Firebox Boiler

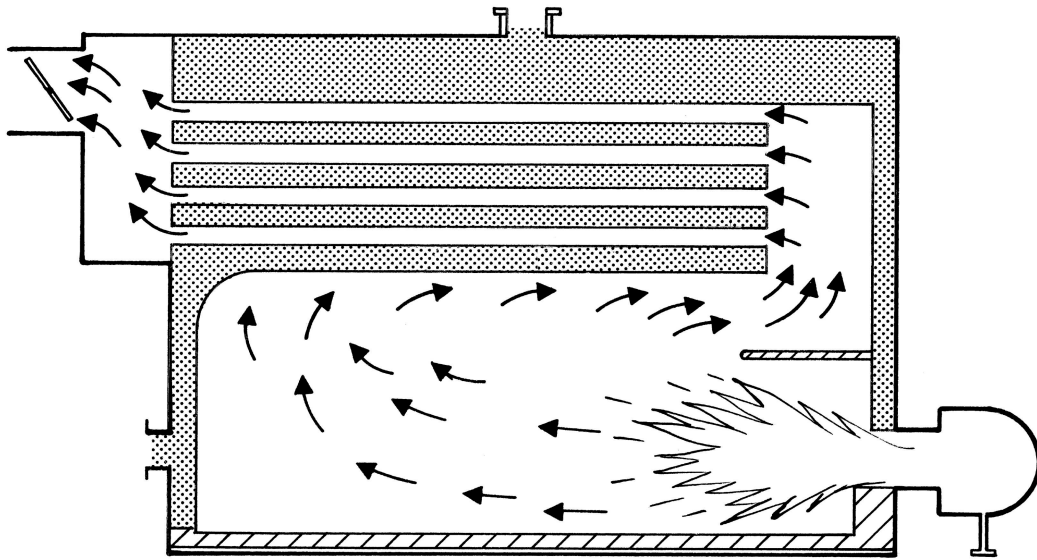

Figure 3.3.1.1.3-2 Three-Pass Firebox Boiler

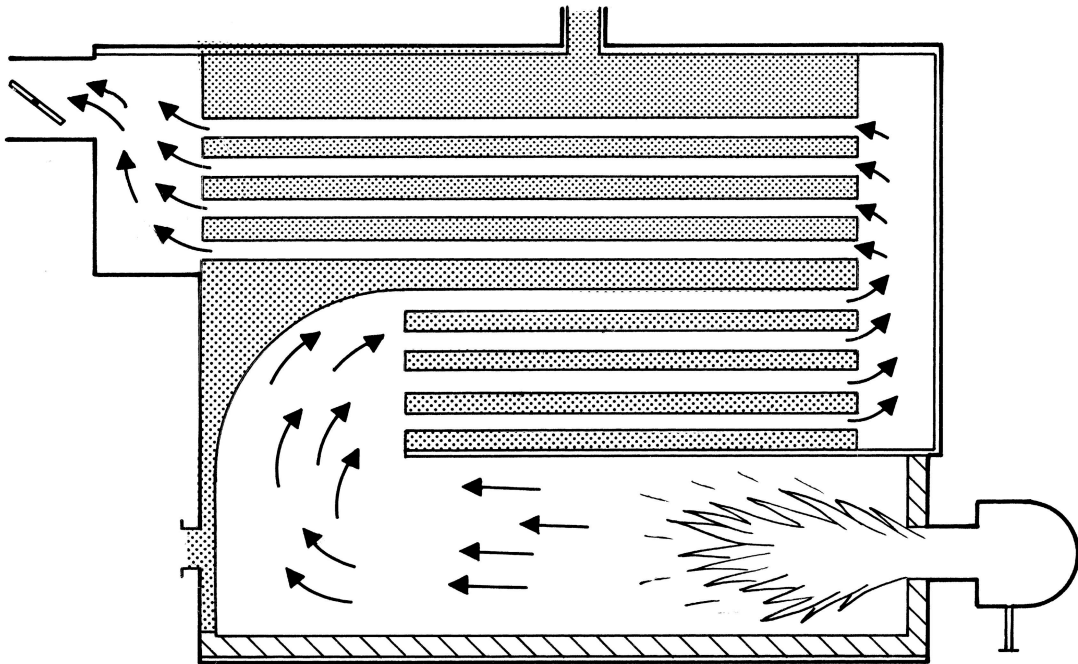

Figure 3.3.1.1.4-1 Vertical Firetube Boiler

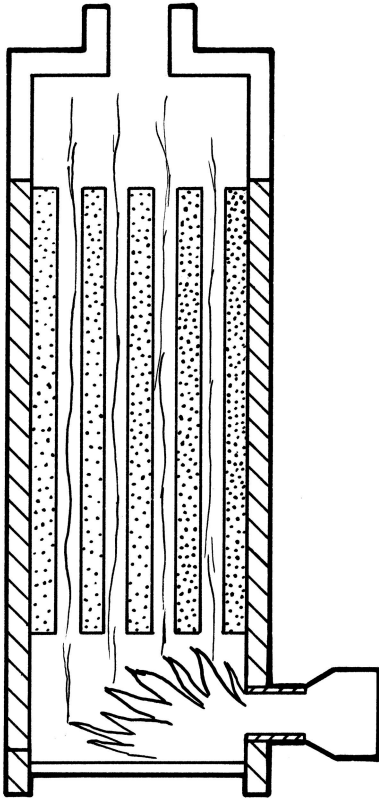

Figure 3.3.2.1-1 Horizontal Sectional Cast Iron Boiler

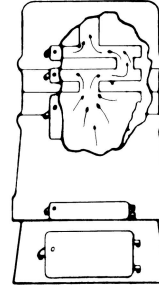
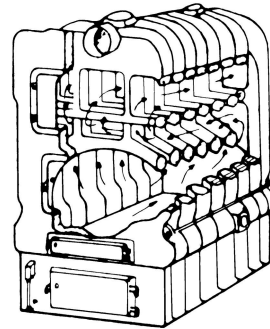

Figure 3.3.2.1-2 Vertical Sectional Cast Iron Boiler



ARTICLE 4

FUELS AND FUEL-BURNING EQUIPMENT

4.1 TYPES OF FUELS

Fuels for boilers are available in gaseous, liquid, or solid form, and some boilers use electricity as their heat source. Care must be taken to ensure that the boiler, burner, and ancillary equipment are designed for the fuel to be utilized.

4.1.1 Gaseous Fuels

4.1.1.1 Natural Gas. Natural gas used for fuel has a wide range of heating values. Methane is the principle component of natural gas, but ethane, propane, and butane may also be present, along with trace amounts of other hydrocarbons. The heating value of the gas depends on the percent of each hydrocarbon present in the mixture, but it typically varies from a low of 950 Btu/ft³ (35.4 MJ/m³) to a high of 1,150 Btu/ft³ (42.9 MJ/m³).

4.1.1.2 Manufactured Gas. Manufactured gas should not be confused with natural gas since manufactured gas, or artificial gas as it is sometimes called, is produced from coal, coal-and-oil mixtures, or petroleum. The heating value of manufactured gas ranges from a low of 350 Btu/ft³ (13.0 MJ/m³) to a high of 600 Btu/ft³ (22.4 MJ/m³).

4.1.1.3 Digester Gas. Digester gas, or biogas as it is sometimes called, is produced by the breakdown of organic matter in the absence of oxygen. It is a renewable energy source and is composed primarily of methane and carbon dioxide with trace amounts of hydrogen and nitrogen. The heating value, which depends mostly upon the methane concentration (typically 40% to 70% by volume), varies from 600 Btu/ft³ (22.4 MJ/m³) to 900 Btu/ft³ (33.6 MJ/m³). The properties of the gas may vary by site. It is important to realize that the gas may be corrosive from either moisture content or the presence of sulfur.

4.1.2 Liquid Fuels

4.1.2.1 Liquefied Petroleum Gas (LPG). Commonly known as propane, liquefied petroleum gas is stored in tanks at high pressure to keep it in a liquid state. Storage may be either above- or belowground, using storage and handling procedures in accordance with the requirements of NFPA 58 and local regulations. When the pressure on the liquefied fuel is reduced to

that required for the burner, the fuel changes from its liquid state to a gas. Propane or butane gas has a heating value of 2,300 Btu/ft³ (85.7 MJ/m³) to 3,300 Btu/ft³ (122.9 MJ/m³). Because of significant heating value differences between liquefied petroleum gas and other gases, the fuel-burning equipment must be modified when changing from the liquefied fuel to another gas, or vice versa. Since propane is colorless and heavier than air, precaution is recommended when working with propane.

4.1.2.2 Fuel Oils. Fuel oils are graded in accordance with specifications of the American Society for Testing and Materials. Oils are classified by their viscosities. Other characteristics of fuel oils that determine their grade, classification, and suitability for given uses are flash point, pour point, water and sediment content, sulfur content, ash, and distillation characteristics. Fuel oils are prepared for combustion in most low-pressure boiler burners by atomization (spraying). The following are commonly used types of atomization:

- (a) high-pressure mechanical atomization
- (b) low-pressure mechanical atomization
- (c) centrifugal atomization (rotary cup)
- (d) compressed air atomization
- (e) steam atomization

4.1.2.2.1 Oil Grade Types

(a) *Grade Number 1.* Grade Number 1 is a light-viscosity distillate oil intended for vaporizing pot-type burners. The heating value is approximately 135,000 Btu/gal (37 600 MJ/m³).

(b) *Grade Number 2.* Grade Number 2 is a distillate oil used for general purpose heating. The heating value is approximately 138,000 Btu/gal (38 500 MJ/m³). This is the most common grade of oil burned in Section IV boilers.

(c) *Grade Number 4.* Grade Number 4 is an oil heavier than Number 2 but not heavy enough to require preheating facilities. Because the oil is no longer available in many locations as a straight-run distillate, but is a mix of Number 2 and heavier oils, it may be necessary in northern climates to provide tank heaters or small recirculating preheaters to ensure delivery of the blended fuel to the burner. If the fuel is not blended properly, the Number 2 oil and the heavier oil may separate in time. Many dealers blend the two grades of oil in the tank truck while delivering to the location. This may result

in physical separation of the two grades if they stand in the tank for any length of time. The heating value is approximately 147,000 Btu/gal (41 000 MJ/m³).

(d) *Grade Number 5.* Grade Number 5 has been divided into hot Number 5 and cold Number 5. The “hot” grade requires preheating and the “cold” may be burned as is from the tank, but because of the increased demand for distillate products, the residual oils may be lower in quality and may require preheating for good results. Sometimes Grade Number 5 is a mix of Number 2 and Number 6. The usual heating value is approximately 152,000 Btu/gal (42 400 MJ/m³).

(e) *Grade Number 6.* Grade Number 6 is a residual-type oil for use in burners equipped with recirculating preheaters. Number 6 fuel oil is sometimes referred to as Bunker C. The typical heating value is approximately 153,000 Btu/gal (42 600 MJ/m³).

4.1.2.2.2 Preheating Requirements. The correct temperature range must be used for each grade of preheated oil. Preheating at too low of a temperature will negatively affect atomization and may cause poor combustion, smoke, and high fuel consumption. Preheating at too high of a temperature can cause the oil to coke in the burner. The oil delivered to the burner must be preheated to the temperature recommended by the burner manufacturer for the grade of fuel used.

4.1.2.2.3 Biodiesel. Biodiesel is a biodegradable, nontoxic, clean-burning fuel that can be made from any fat or vegetable oil, including recycled cooking oil.

4.1.3 Solid Fuels

4.1.3.1 Coal. Coal comes in various grades with a wide range of heating values. Coals are ranked according to their content, in percent by weight, of volatile matter, fixed carbon, ash, and moisture. While coal ranking cannot be totally defined by any one of these items, typically coals with high levels of fixed carbon tend to have higher heating values than those with lower fixed-carbon percentages, and high levels of moisture tend to reduce the heating value.

4.1.3.1.1 Anthracite Coal. Anthracite coal is dense, stonelike in structure, and shiny black in color. Because of its hardness, it can be handled with little breakage. When ignited, it burns freely with a short, relatively smokeless flame and does not coke. It has very little volatile matter and is commonly referred to as hard coal. Semianthracite is not as hard as anthracite and is higher in volatile matter. It is dark gray in color and of granular structure. Semianthracite swells considerably in size when burning, but it does not coke. The heating value of anthracite and semianthracite coals, as received, is 12,000 Btu/lb (29.7 MJ/kg) to 13,000 Btu/lb (30.2 MJ/kg).

4.1.3.1.2 Bituminous Coal. This classification covers a wide range of coals, from the high grades found in the eastern part of the United States to the lower grades found in the western regions. Bituminous coal, commonly called soft coal, is the most extensively used of all coals. The various types of soft coal differ in composition, properties, and burning characteristics. Some are firm in structure and present no handling problem, while others tend to break when handled. Bituminous coal ignites rather easily and burns readily, usually with a long flame. Medium-volatile and high-volatile coals coke in the fire and smoke when improperly burned. The “as received” heating value of bituminous coals varies from approximately 10,500 Btu/lb (24.2 MJ/kg) to 14,500 Btu/lb (33.7 MJ/kg).

4.1.3.1.3 Subbituminous Coal. Subbituminous coal is noncoking and is black in color, similar to bituminous coal. This type of coal is high in volatile matter and ignites easily; it also has a tendency toward spontaneous combustion when drying. Subbituminous coal has a low sulfur content, often less than 1%, and its heating value ranges from 8,300 Btu/lb (19.3 MJ/kg) to 11,500 Btu/lb (26.7 MJ/kg).

4.1.3.1.4 Lignite. Lignite is sometimes referred to as brown coal and is primarily found in the western United States. This type of coal has a relatively low heating value, typically between 4,300 Btu/lb (10.0 MJ/kg) and 8,600 Btu/lb (20 MJ/kg). The heating value depends upon the moisture content, which can reach as high as 66%, and ash content, which can vary from 6% to 19%. The relatively high moisture content makes it susceptible to spontaneous combustion, which can cause problems in storage and transportation. The use of lignite is usually feasible only where other types of coal are not available and large deposits are relatively close to the point of use.

4.1.3.1.5 Pulverized Coal. Pulverized coal is coal that has been crushed and dried. Like liquids and gaseous fuels, it can be transported through pipes. Due to its extremely volatile nature, extreme care should be exercised when handling this fuel. High- and medium-volatile bituminous coals are commonly pulverized, and the degree of fineness is dependent upon the type of coal being pulverized. The density of pulverized coal varies from 35 lb/ft³ (561 kg/m³) to 55 lb/ft³ (881 kg/m³), and the heating value varies from 11,000 Btu/lb (25.6 MJ/kg) to 12,900 Btu/lb (30 MJ/kg).

4.1.3.2 Wood. Wood has been used for centuries for fuel and continues to be used today where firewood is abundant and transportation costs are relatively low. Wood is typically sold by the cord, which is a wood pile 8 ft × 4 ft × 4 ft. The moisture content of the wood greatly influences the heat content, which can vary from 6,400 Btu/lb (14.9 MJ/kg) to 8,000 Btu/lb

(18.6 MJ/kg). Handling costs for both the wood and the ash it produces can make the use of wood for energy generation more costly than the use of other fuels.

4.1.4 Electricity

Although electricity is in itself not a fuel, it is used as a source of heat for heating boilers. The two general methods of application are electrodes and immersed direct-resistance elements. When electrodes are used, the boiler water serves as the heating element by offering resistance to the passage of current between the immersed electrodes. Direct-resistance elements create heat by the resistance offered to the passage of electric current through the immersed element.

4.2 FUEL-BURNING EQUIPMENT

4.2.1 Gas-Burning Equipment

Gas-burning equipment can be an atmospheric or power burner (natural draft or forced-draft) or a combination burner.

4.2.1.1 Atmospheric Burners. Atmospheric burners depend upon natural draft for combustion air. There are several types of atmospheric burners, most of which fall into the general classifications of single- or multiport type.

4.2.1.2 Power Burners. Power burners depend on a blower to supply combustion air and include the following types:

(a) *Natural Draft Burners.* Natural draft burners operate with a furnace pressure slightly less than atmospheric. The proper draft condition is maintained by either natural draft or an induced-draft fan.

(b) *Forced-Draft Burners.* Forced-draft burners are designed to operate with a furnace pressure higher than atmospheric. These burners are equipped with sufficient blower capacity to force products of combustion through the boiler without the help of natural or induced draft.

4.2.1.3 Combination Fuel Burners. Combination fuel burners are designed to burn more than one fuel, with either manual or automatic switchover from one fuel to another.

4.2.2 Liquid-Burning Equipment

An oil burner mechanically mixes fuel oil and air for combustion under controlled conditions. Ignition is accomplished by an electric spark, electric resistance wire, gas pilot flame, or oil pilot flame.

4.2.2.1 Pressure-Atomizing Burners (Gun Type). Pressure-atomizing burners (gun type) are divided into two classes: high-pressure and low-pressure mechanical atomization.

(a) The high-pressure mechanical-atomizing type is characterized by an air tube, usually horizontal, with a pressurized oil supply centrally located in the tube and arranged so that a spray of atomized oil is introduced at approximately 100 psig (700 kPa) and mixed in the combustion chamber with the airstream emerging from the air tube. The oil is supplied to the burner by a fuel delivery unit that serves as a pressure-flow-regulating device as well as a pumping device. Where electric ignition is employed, a high-voltage transformer is used to supply approximately 10,000 V to create an ignition arc across a pair of electrodes located above the nozzle. Where gas ignition is employed on a larger burner, a gas pilot is used. The firing rate is governed by the size of the nozzle used. Multiple nozzles are used on some of the larger burners, and variable flow nozzles are used on others. A low-fire start on a modulating burner that employs a variable flow nozzle is accomplished by supplying the oil at a reduced pressure. A low-fire start on a multiple-nozzle burner is accomplished by permitting oil flow to only one or two of the nozzles.

(b) The low-pressure atomizing burner differs from the high-pressure type mainly by having means for supplying a mixture of oil and primary air to the burner nozzle. The air meeting the mixture in the furnace is “secondary air” that provides for complete combustion. The air pressure before mixing and the pressure of the air-oil mixture vary with different makes of burners but are in the low range of 1 psig to 15 psig (7 kPa to 100 kPa) for air and 2 psig to 7 psig (14 kPa to 48 kPa) for the mixture. Capacity of the burners is varied by making pump stroke or orifice changes on the oil pumps.

4.2.2.2 Steam-Atomizing Burners. Steam-atomizing burners use steam to atomize heavy-grade fuel oil. Steam is usually supplied by the boiler being operated.

4.2.2.3 Air-Atomizing Burners. In this type of burner, the compressed air or steam is used as the atomizing medium. An air compressor is usually provided as part of the burner, although the air may be supplied from another source.

4.2.2.4 Horizontal Rotary Cup Burner. The horizontal rotary cup burner uses the principle of centrifugal atomization. The oil is prepared for combustion by centrifugal force, which spins it off a cup rotating at high speed into an airstream, causing the oil to break up into a spray. This type can be used with all grades of fuel oil. Modulated firing can be provided on these burners.

4.2.3 Solid-Fuel-Burning Equipment

Generally, stokers are used when burning coal or wood. Stokers provide a mechanical means for feeding the fuel and supplying combustion air. They are built in several

types, the most common of which are underfeed, spreader, and chain grate. Pulverized coal is transported in a manner similar to that used for a liquid and is burned in suspension as it is sprayed into the combustion chamber.

ARTICLE 5

BOILER ROOM FACILITIES AND INSTALLATION

5.1 GENERAL

5.1.1 Scope

This Article covers the recommended procedures for the safe, economical operation and maintenance of automatically fired boilers.

5.1.2 Intention

It is not intended that this Article serve as operating instructions for any specific heating plant. Due to the wide variety of types and makes of equipment used, this Article should be supplemented with equipment manufacturers' instructions concerning maintenance and care and specific written operating instructions for each system.

5.1.3 Installation

Heating boilers should be installed in accordance with the rules and regulations of the local jurisdiction, most of which have adopted nationally recognized standards that must be followed. However, in the absence of local jurisdictional rules, the following national standards and codes may be used for the installation of heating boilers:

ANSI Z21.13/CSA 4.9, Gas-Fired Low Pressure Steam and Hot Water Boilers

Publisher: The American National Standards Institute (ANSI), 25 West 43rd Street, New York, NY 10036 (www.ansi.org)

ASME B31.9, Building Service Piping

ASME CSD-1, Controls and Safety Devices for Automatically Fired Boilers

Publisher: The American Society of Mechanical Engineers (ASME), Two Park Avenue, New York, NY, 10016-5990 (www.asme.org)

NBBI NB-23, National Board Inspection Code (NBIC), Part 1, Installation

Publisher: National Board of Boiler and Pressure Vessel Inspectors (NBBI), 1055 Crupper Avenue, Columbus, OH 43229 (www.nationalboard.org)

NFPA 31, Standard for the Installation of Oil-Burning Equipment

NFPA 54, National Fuel Gas Code

NFPA 85, Boiler and Combustion Systems Hazards Code
 Publisher: National Fire Protection Association (NFPA),
 1 Batterymarch Park, Quincy, MA 02169
 (www.nfpa.org)

UL 834, Heating, Water Supply, and Power Boilers — Electric

Publisher: Underwriter Laboratories, Inc. (UL), 333 Pfingsten Road, Northbrook, IL 60062-2096; Order Address: Comm 2000, 151 Eastern Avenue, Bensenville, IL 60106 (www.ul.com)

5.1.4 New Boilers — Acceptance and Examination

5.1.4.1 Examination for Contractual Acceptance.

Before any new heating plant (or boiler) is accepted for operation, a final (or acceptance) review should be completed by the owner or their representative, and all items of exception corrected by the installation contractor. The review should confirm that all equipment called for is furnished and installed in accordance with the plans and the Manufacturer's instructions and specifications, and should include a test of all controls by a person familiar with the control system.

5.1.4.2 Operational Examination. Before a boiler is put into operation for the first time, it should be examined as required by law. Subsequent examinations should also be made as required by local law. The insurance company insuring the boiler may be able to provide guidance on the applicable law.

5.2 LIGHTING

The boiler room should be well lit to allow safe operation of all equipment, entry, and exit. Proper lighting will allow the operator to visually examine all instrumentation and safety controls, and to check for any abnormal condition. The boiler room should have an emergency light source in case of power failure.

5.3 VENTILATION AND COMBUSTION AIR

5.3.1 Combustion Air

The boiler room must have an adequate air supply to permit clean, safe combustion to minimize soot formation and maintain a minimum of 19.5% oxygen in the air of the

boiler room. The combustion and ventilation air may be supplied by either an unobstructed air opening or power ventilation fans.

5.3.2 Air Openings

Unobstructed air openings should be sized on the basis of 1 in.² (650 mm²) free area per 2,000 Btu/hr (0.586 kW) maximum fuel input of the combined burners located in the boiler room or as specified by the National Fire Protection Association (NFPA) standards for oil- and gas-burning installation for the particular job conditions. The boiler room air supply openings must be kept clear at all times. The National Board Inspection Code and the Manufacturer's instruction should also be referenced for additional guidance.

5.4 CLEARANCES

Heating boilers should be located so as to provide adequate space for proper operation, maintenance, and examination of equipment and appurtenances. Clearances should be provided in accordance with the Manufacturer's instructions, subject to acceptance by the jurisdiction.

5.5 FIRE PROTECTION

Fire protection apparatus and fire prevention procedures for boiler room areas should conform to the recommendations of NFPA and local jurisdictional requirements.

5.6 ELECTRICAL SUPPLY

5.6.1 Wiring

All wiring for controls, heat-generating apparatus, and other appurtenances necessary for the operation of the boiler(s) must be installed in accordance with provisions of national or international standards and comply with the applicable local electrical codes.

5.6.2 Switches or Circuit Breakers

A manually operated remote heating plant shutdown switch or circuit breaker should be located just outside the boiler room door and marked for easy identification. Consideration should also be given to the type and location of the switch to safeguard against tampering. If the boiler room door is on the building exterior, the switch should be located just inside the door. If there is more than one door to the boiler room, there should be a switch located at each door.

5.6.2.1 For oil burners where the fan is on a common shaft with the oil pump, the complete burner and controls should be shut off.

5.6.2.2 For power burners with detached auxiliaries, only the fuel input supply to the boiler need be shut off.

5.7 FUEL SUPPLY

Fuel systems, whether firing gas, oil, coal, or other substances, should be installed in accordance with jurisdictional and environmental requirements, Manufacturer's instructions, and/or industry standards, as applicable.

5.8 CHIMNEY OR VENT

5.8.1 Installation

Chimneys or vents should be installed in accordance with jurisdictional requirements, Manufacturer's recommendations, and/or industry standards, as applicable. All possible draft conditions (based on modulation and quantity of boilers) should be considered when designing/installing the exhaust vent. It is important to locate exhaust vents in such a way that they do not become blocked by snow, ice, or other natural or man-made obstructions. The vent material used must be in compliance with the Manufacturer's instructions.

5.8.2 Handling of Condensate

Condensing boilers are listed as either Category II (negative pressure, condensing) or Category IV (positive pressure, condensing) appliances, and venting material should be listed and labeled to the appropriate UL specification. Follow the boiler Manufacturer's recommendations for provisions for trapping and draining condensate. Care must be taken to ensure that the condensate drain piping is not exposed to temperatures where water/condensate will freeze in the lines. Condensate may require pH neutralization. Consult local authorities for jurisdictional requirements.

5.9 PIPING — WATER AND DRAIN CONNECTIONS

5.9.1 General

Figures 5.9.1-1 through 5.9.1-5 show recommended piping arrangements. Guidance for the design of piping systems may be found in ASME B31.9.

5.9.2 Provisions for Expansion and Contraction

The following provisions should be made for the expansion and contraction of steam and hot water mains connected to boilers:

(a) Pipe connections should be substantially anchored at suitable points.

(b) Swing or expansion joints should be used so there will be no undue stress transmitted to the boiler(s).

Figure 5.9.1-1 Single Hot Water Heating Boiler — Acceptable Piping Installation

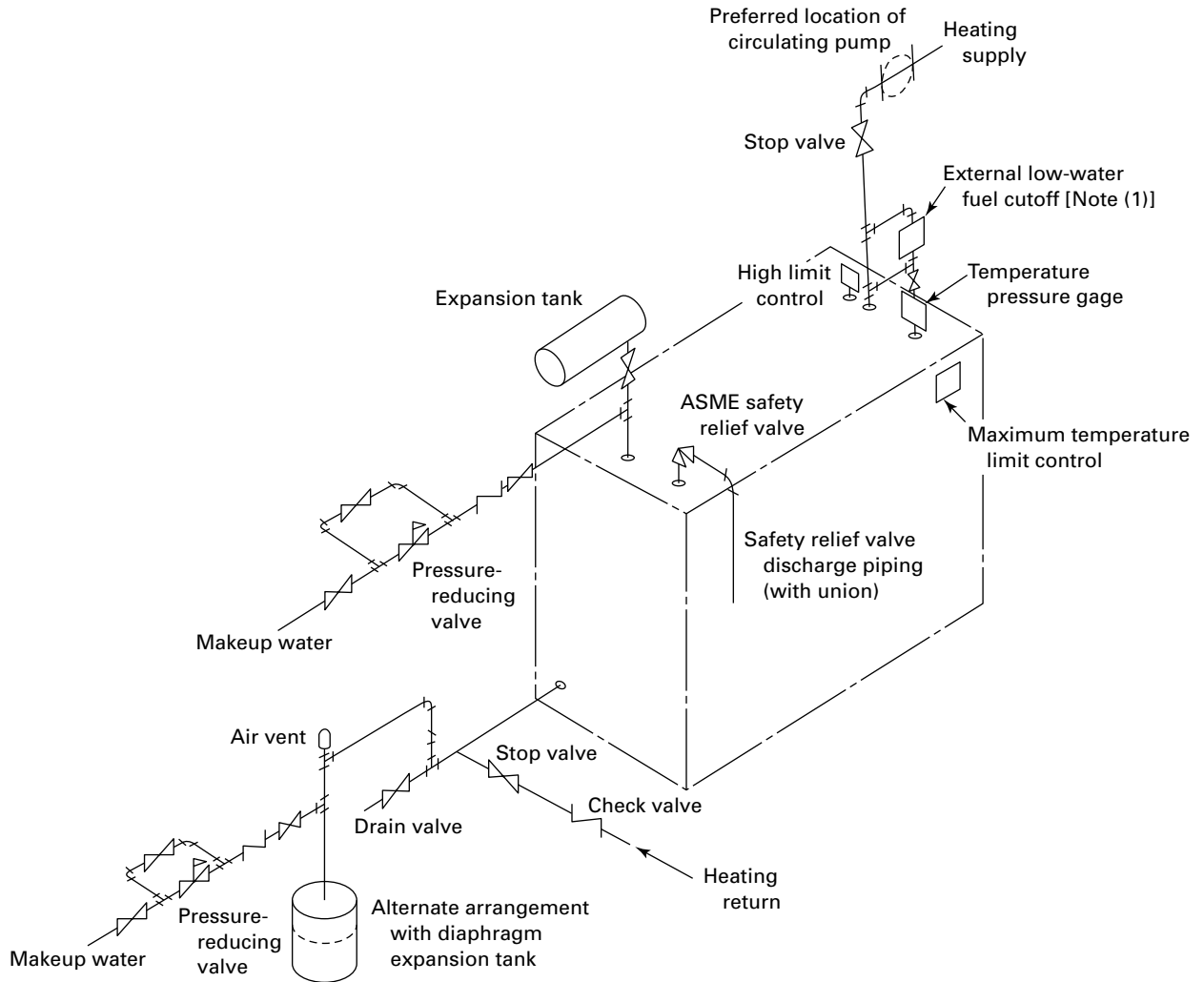

GENERAL NOTE: Plumbing codes may require the installation of a reduced-pressure principle backflow preventer on a boiler when the makeup water source is from a potable water supply.

NOTE: (1) Recommended control. See 8.5.1. Acceptable shutoff valves or cocks in the connecting piping may be installed for convenience of control testing and/or service.

Figure 5.9.1-2 Hot Water Heating Boilers in Battery — Acceptable Piping Installation

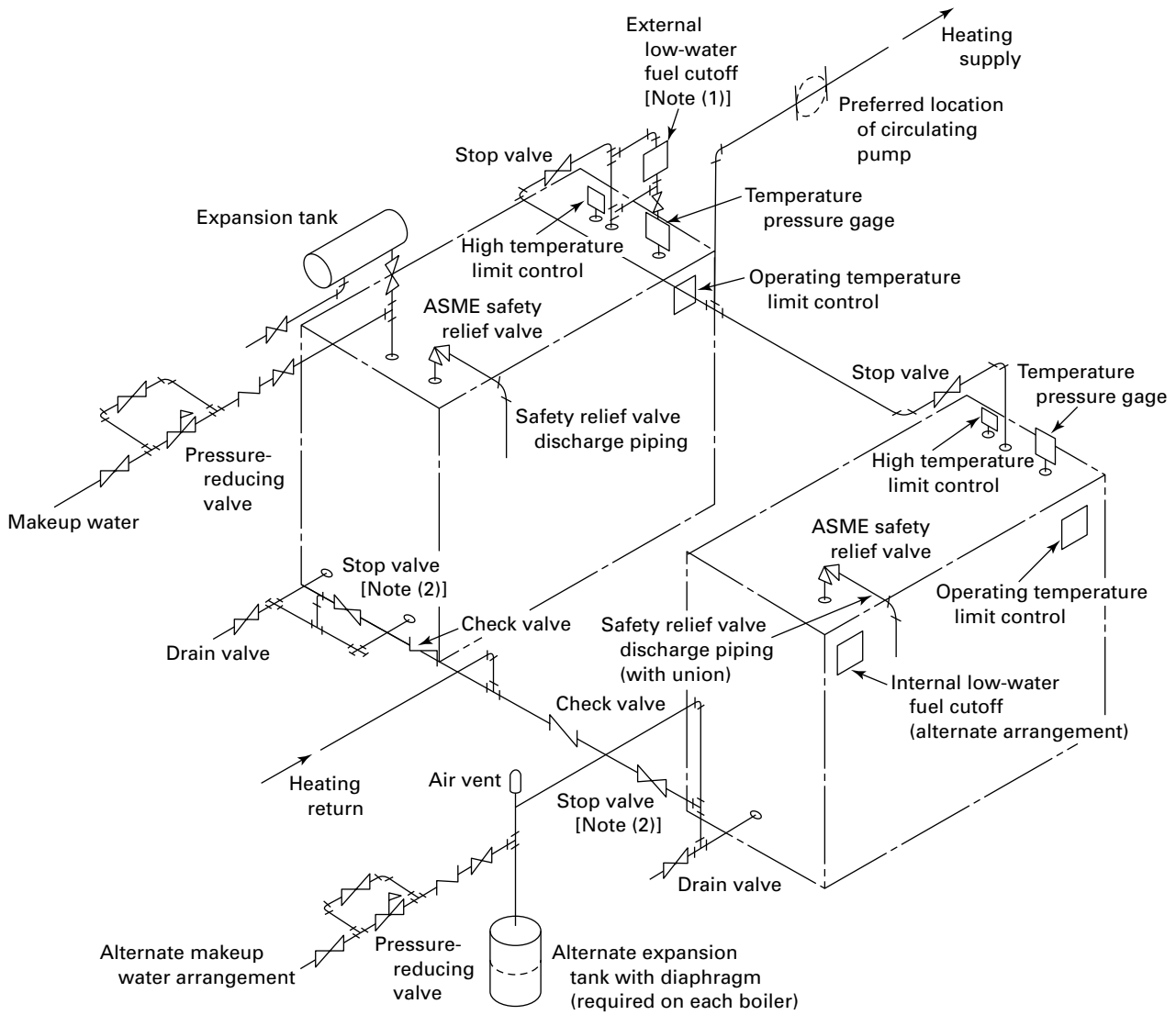

GENERAL NOTE: Plumbing codes may require the installation of a reduced-pressure principle backflow preventer on a boiler when the makeup water source is from a potable water supply.

NOTES:

- (1) Recommended control. See 8.5.1. Acceptable shutoff valves or cocks in the connecting piping may be installed for convenience of control testing and/or service.
- (2) The common return header stop valves may be located on either side of the check valves.

Figure 5.9.1-3 Single Steam Boilers — Acceptable Piping Installation

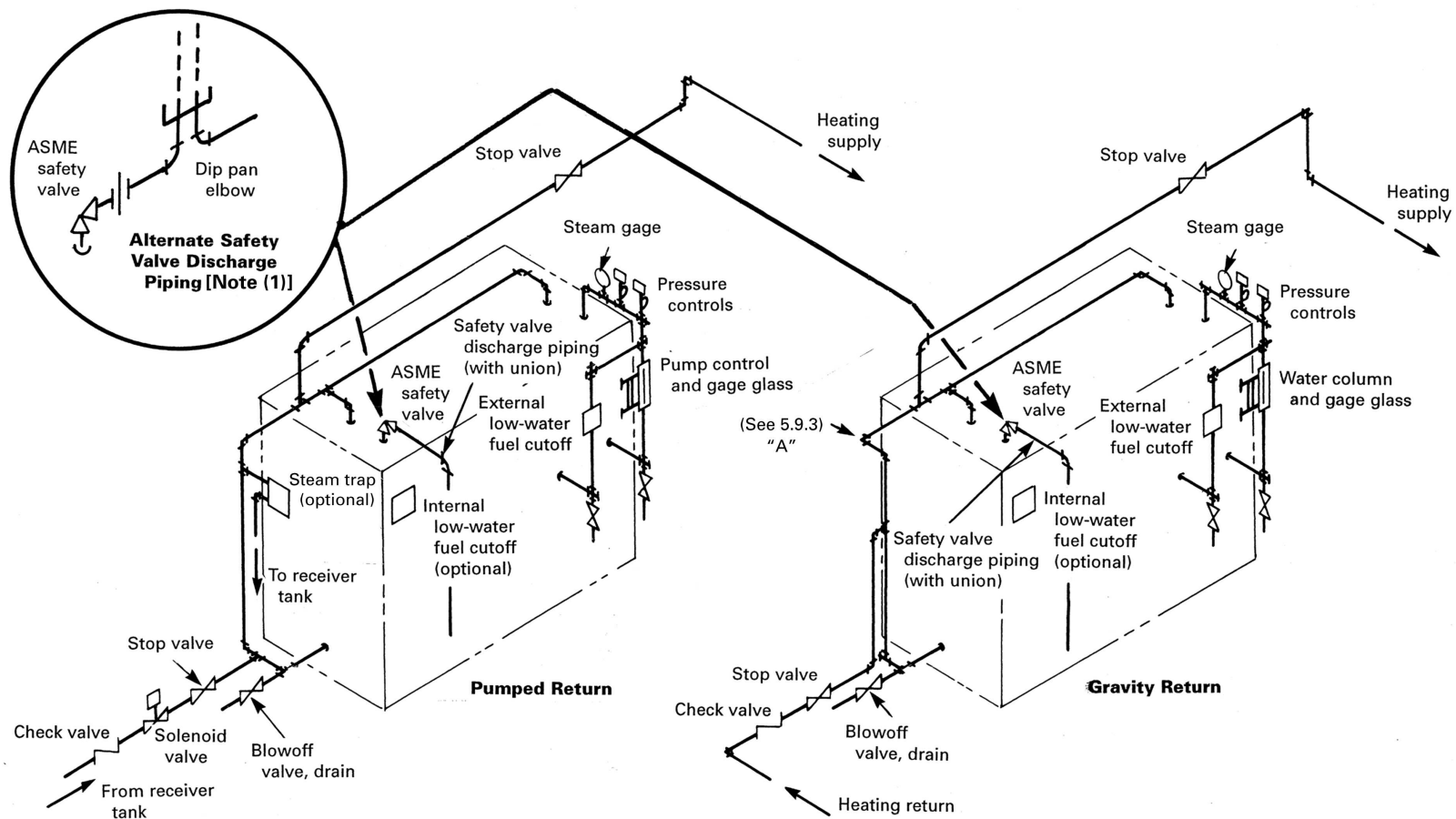

19

ASME BPVC:VI-2021

GENERAL NOTES:

- (a) Plumbing codes may require the installation of a reduced-pressure principle backflow preventer on a boiler when the makeup water source is from a potable water supply.
- (b) Return loop connection was designed to eliminate the necessity of check valves on gravity return systems, but in some localities a check valve is a legal requirement.
- (c) When pump discharge piping exceeds 25 ft (7.6 m), install swing check valves at pump discharge.
- (d) If pump discharge is looped above normal boiler waterline, install a spring-loaded check valve at return header and at pump discharge.
- (e) Where supply pressures are adequate, makeup water may be introduced directly to a boiler through an independent connection.

NOTE: (1) Recommended for 1-in. (25-mm) and larger safety valve discharge.

Figure 5.9.1-4 Steam Boilers in Battery — Pumped Return — Acceptable Piping Installation

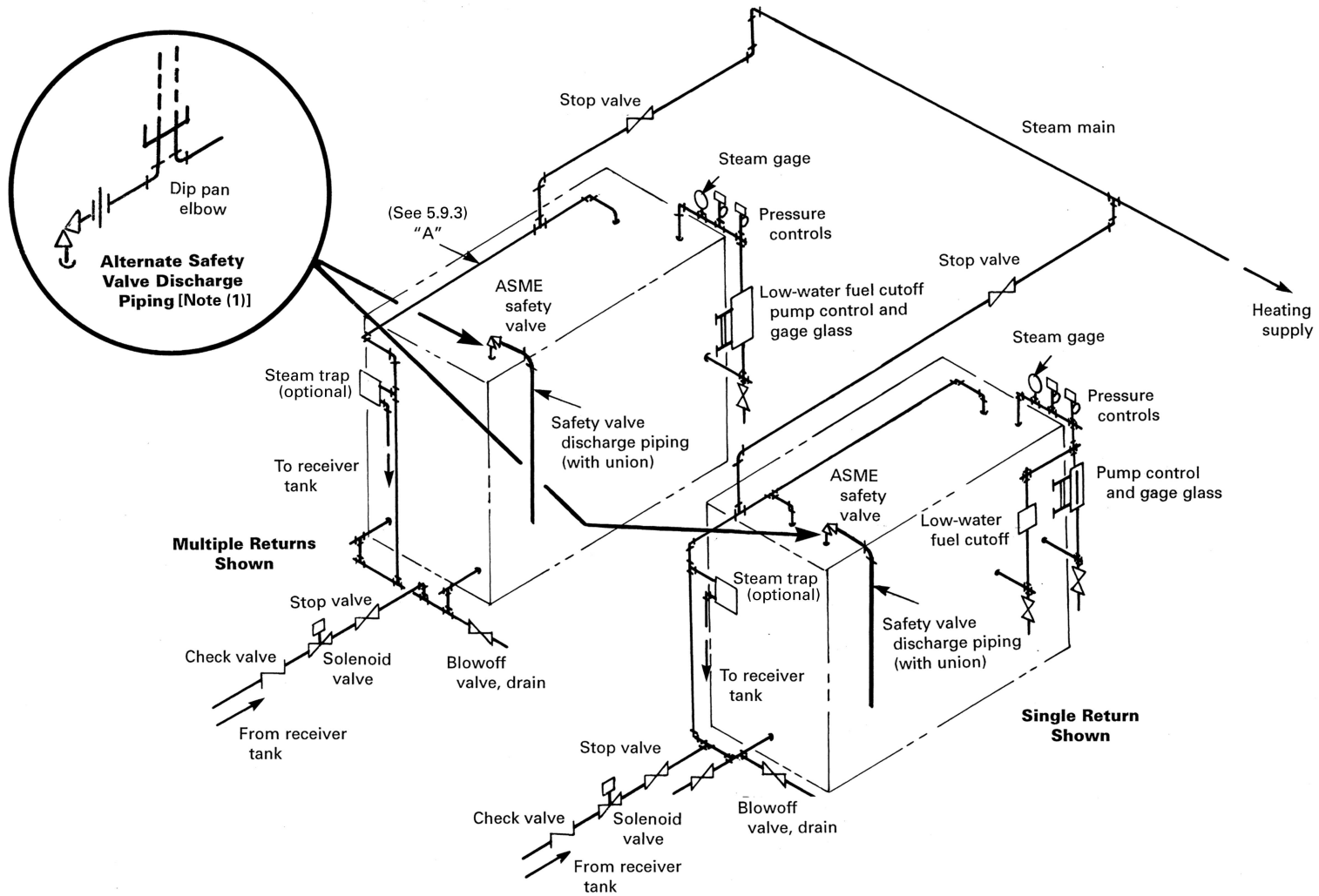

GENERAL NOTES:

- (a) Return connections shown for a multiple-boiler installation may not always ensure that the system will operate properly. To maintain proper water levels in multiple-boiler installations, it may be necessary to install supplementary controls or suitable devices.
- (b) Plumbing codes may require the installation of a reduced-pressure principle backflow preventer on a boiler when the makeup water source is from a potable water supply.

NOTE: (1) Recommended for 1-in. (25-mm) and larger safety valve discharge.

Figure 5.9.1-5 Steam Boilers in Battery — Gravity Return — Acceptable Piping Installation

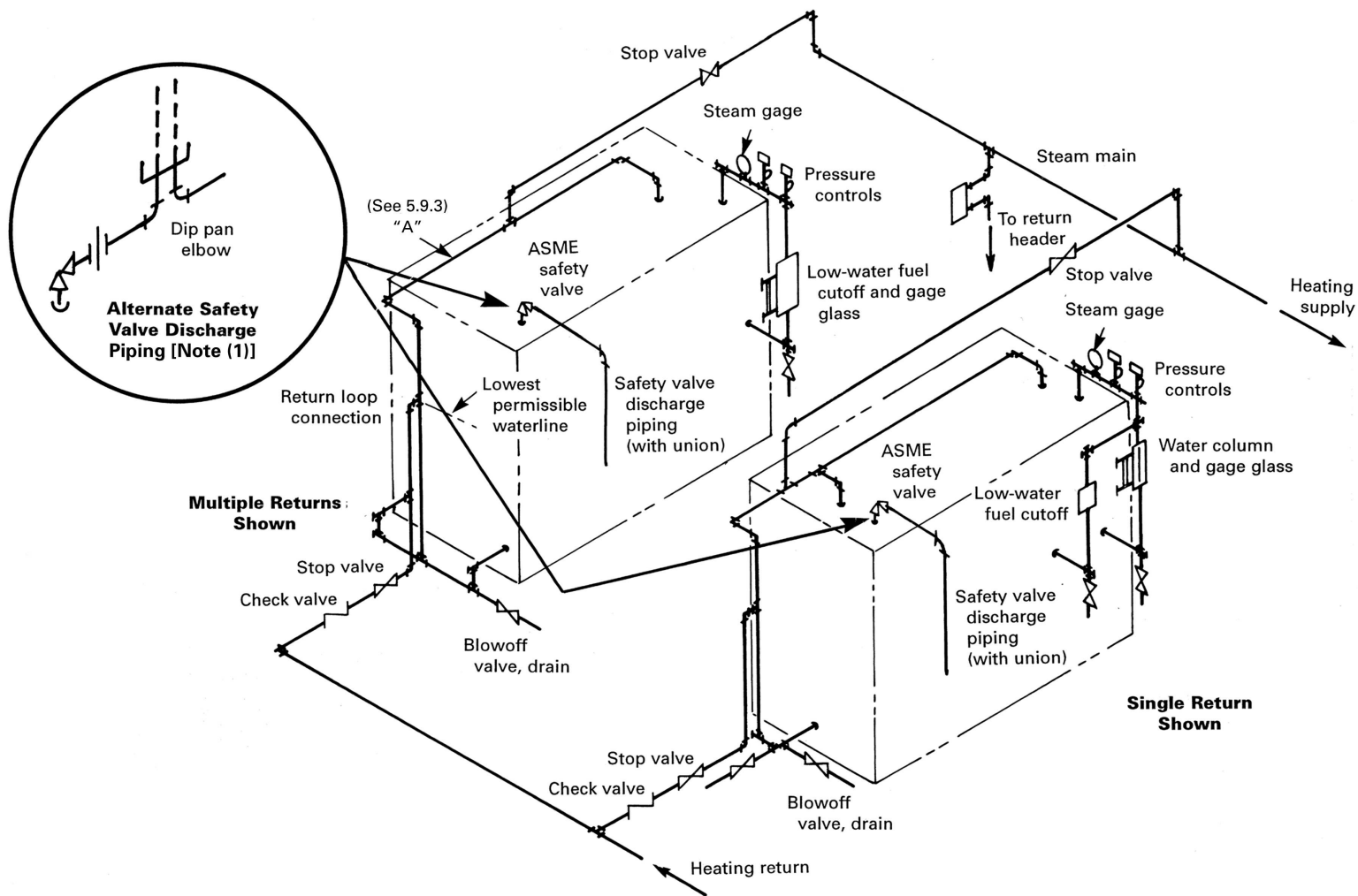

GENERAL NOTES:

- (a) Return connections shown for a multiple-boiler installation may not always ensure that the system will operate properly. To maintain proper water levels in multiple-boiler installations, it may be necessary to install supplementary controls or suitable devices.
- (b) Plumbing codes may require the installation of a reduced-pressure principle backflow preventer on a boiler when the makeup water source is from a potable water supply.

NOTE: (1) Recommended for 1-in. (25-mm) and larger safety valve discharge.

5.9.3 Steam Boiler Return Pipe Connections

5.9.3.1 The return pipe connections of each boiler supplying a gravity-return steam-heating system shall be so arranged as to form a loop similar to that shown in Figures 5.9.1-3 and 5.9.1-5 so that the water in each boiler cannot be forced out below the safe water level.

5.9.3.2 For hand-fired boilers with a normal grate line, the recommended pipe sizes detailed as “A” in Figure 5.9.1-3 are as follows:

- (a) NPS 1½ (DN 40) for 4 ft² (0.4 m²) or smaller firebox area at the normal grate line
- (b) NPS 2½ (DN 65) for areas larger than 4 ft² (0.4 m²) up to 15 ft² (1.4 m²)
- (c) NPS 4 (DN 100) for 15 ft² (1.4 m²) or larger

5.9.3.3 For automatically fired boilers that do not have a normal grate line, the recommended pipe sizes detailed as “A” in Figure 5.9.1-3 are

- (a) NPS 1½ (DN 40) for boilers with a minimum safety valve relieving capacity of 250 lb/hr (113 kg/h) or less
- (b) NPS 2½ (DN 65) for boilers with a minimum safety valve relieving capacity of 251 lb/hr (114 kg/hr) to 2,000 lb/hr (900 kg/h), inclusive
- (c) NPS 4 (DN 100) for boilers with a minimum safety valve relieving capacity greater than 2,000 lb/hr (900 kg/h)

5.9.3.4 Provision shall be made for cleaning the interior of the return piping at or close to the boiler. Washout openings may be used for return pipe connections and the washout plug placed in a tee or a cross so that the plug is directly opposite and as close as possible to the opening in the boiler.

5.9.4 Feedwater and Makeup Water Connections

5.9.4.1 Water Connections. Proper and convenient water-fill connections should be installed, and provisions should be made to prevent boiler water from backfeeding into the service water supply. Provision should also be made in every boiler room for a convenient water supply that can be used to flush out the boiler and clean the boiler room floor. Water piping should be installed such that the boiler is not supporting the piping. Refer to the Manufacturer’s instructions for information regarding required water flow rates and supply pressure so that piping is sized accordingly.

5.9.4.2 Steam Boilers. Feedwater or water treatment shall be introduced into a boiler through the return piping system or through an independent connection. The water flow from the independent connection shall not discharge directly against parts of the boiler exposed to direct radiant heat from the fire. Feedwater or water treatment shall not be introduced through openings or connections provided for inspection or cleaning of the safety valve, blowoff, water column, water gauge glass, or pressure

gauge. The pipe shall be provided with a check valve or a backflow preventer containing a check valve near the boiler and a stop valve or cock between the check valve and the boiler or between the check valve and the return piping system.

5.9.4.3 Hot Water Boilers. Makeup water may be introduced into a boiler through the piping system or through an independent connection. The water flow from the independent connection shall not discharge directly against parts of the boiler exposed to direct radiant heat from the fire. Makeup water shall not be introduced through openings or connections provided exclusively for inspection or cleaning of the safety relief valve, pressure gauge, or temperature gauge. The makeup water pipe shall be provided with a check valve or a backflow preventer containing a check valve near the boiler and a stop valve or cock between the check valve and the boiler or between the check valve and the return piping system.

5.9.4.4 Valve Ratings. The minimum pressure rating of all check valves, stop valves, cocks, or backflow preventers with check valve(s) shall be not less than the pressure rating stamped on the boiler, and the temperature rating of such check valves, cocks, or backflow preventers, including all internal components, shall be not less than 250°F (120°C).

5.9.4.5 Backflow Preventer. Some jurisdictions may require installation of a backflow preventer in the feed-water connection.

5.9.5 Bottom Blowoff Valve

Each steam boiler shall have a bottom blowoff connection fitted with a valve or cock connected to the lowest water space practicable with a minimum size as shown in Table 5.9.5-1. The discharge piping shall be full size to the point of discharge. Boilers having a capacity of 25 gal (91 L) or less are exempt from these requirements,

Table 5.9.5-1 Size of Bottom Blowoff Piping, Valves, and Cocks

Minimum Required Safety Valve Capacity, lb (kg) of Steam/hr [Note (1)]	Blowoff Piping, Valves, and Cocks Min. Size, NPS (DN)
Up to 500 (226)	¾ (20)
501 to 1,250 (227 to 567)	1 (25)
1,251 to 2,500 (568 to 1 134)	1¼ (32)
2,501 to 6,000 (1 135 to 2 721)	1½ (40)
6,001 (2 722) and larger	2 (50)

NOTE: (1) To determine the discharge capacity of safety relief valves in terms of Btu, the relieving capacity in lb of steam/hr is multiplied by 1,000.

except that they must have a NPS $\frac{3}{4}$ (DN 20) minimum drain valve.

5.9.6 Drains

Each steam or hot water boiler may have one or more drain connections piped to a floor drain.

5.9.6.1 Drain Connections. Proper and convenient drain connections should be provided for draining boilers. Unobstructed floor drains, properly located in the boiler room, facilitate proper cleaning of the boiler room. Floor drains that are used infrequently should have water poured into them periodically to prevent the entrance of sewer gases and odors. If there is a possibility of freezing, an antifreeze mixture should be used in the drain traps.

5.9.6.2 Drain Valve. Each steam or hot water boiler shall have one or more drain connections fitted with valves or cocks connecting to the lowest water-containing spaces. The minimum size of the drain piping shall be NPS $\frac{3}{4}$ (DN 20). The discharge piping shall be full size to the point of discharge. When the blowoff connection is located at the lowest water-containing space, a separate drain connection is not required. The minimum pressure rating of valves and cocks used for blowoff or drain purposes shall be not less than the pressure rating stamped on the boiler but in no case shall it be less than 30 psi (200 kPa). The temperature rating of such valves and cocks shall be not less than 250°F (120°C). Many jurisdictions have requirements stipulating the maximum temperature and quality of the water going to the drain, which should be considered when installing the equipment.

5.9.6.3 Condensing Boilers. Follow the boiler Manufacturer's instructions for provisions for trapping and draining condensate. Be aware that the condensate can be acidic and may require neutralization or other special handling. Materials compatible with the condensate must be used. Consult local authorities for jurisdictional requirements.

5.9.7 Stop Valves

5.9.7.1 Installation

(a) For single steam boilers, stop valves shall be installed in the supply pipe and return pipe connections to permit testing the safety valve without pressurizing the system.

(b) For single hot water heating boilers, stop valves should be located at an accessible point in the supply and return pipe connections, as near the boiler nozzle as is convenient and practical, to permit the draining of the boiler without draining the system and to permit testing of the safety relief valve without pressurizing the system.

(c) For multiple boiler installations, stop valves should be installed in each supply and return of two or more boilers connected to a common system to permit draining of individual boilers without draining the entire system.

5.9.7.2 Valve Specifications

5.9.7.2.1 All valves or cocks may be ferrous or nonferrous.

5.9.7.2.2 The minimum pressure rating of all valves or cocks shall be not less than the pressure rating stamped on the boiler, and the temperature rating of such valves or cocks, including all internal components, shall be not less than 250°F (120°C).

5.9.7.2.3 Valves may be threaded, flanged, or compression type, or have ends suitable for welding or brazing.

5.9.7.2.4 All valves or cocks with stems or spindles shall have adjustable pressure-type packing glands or self-adjusting seals suitable for the intended service.

All plug-type cocks shall be equipped with a guard or gland suitable for the intended service. All $\frac{1}{4}$ -turn-valve operating mechanisms shall have a tee or lever handle arranged to be parallel to the pipe in which it is located when the cock is open.

5.9.7.2.5 All valves or cocks shall have tight closure when under boiler hydrostatic test pressure.

5.9.8 Modular Boilers

A modular boiler is an assembly of small boilers designed to take the place of a single large boiler. The small boilers are called modules and are intended to be installed as a unit, without any intervening stop valves between the modules, with a single inlet and a single outlet. Modules may be under one jacket or may be individually jacketed. It is important that the Manufacturer's installation instructions be followed to ensure proper assembly, correct control location, and proper flow through each module.

Figures 5.9.8-1 and 5.9.8-2 show the two piping arrangements that are specified by various Manufacturers.

5.9.8.1 Individual Modules

(a) The individual modules shall comply with all the requirements of Section IV, Part HG.

(b) Each module of a modular steam heating boiler shall be equipped with

- (1) steam gauge
- (2) water gauge glass
- (3) operating limit control
- (4) low-water cutoff
- (5) safety valve
- (6) bottom blowoff valve

Figure 5.9.8-1 Modules Connected With Parallel Piping

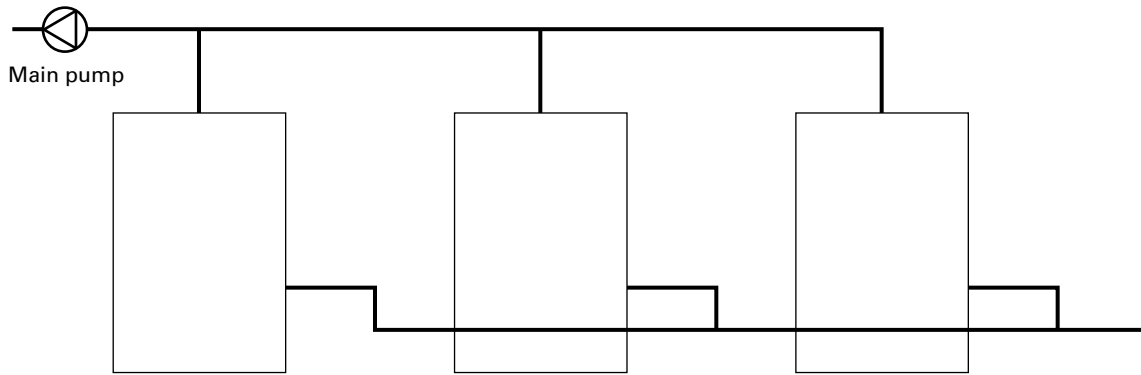
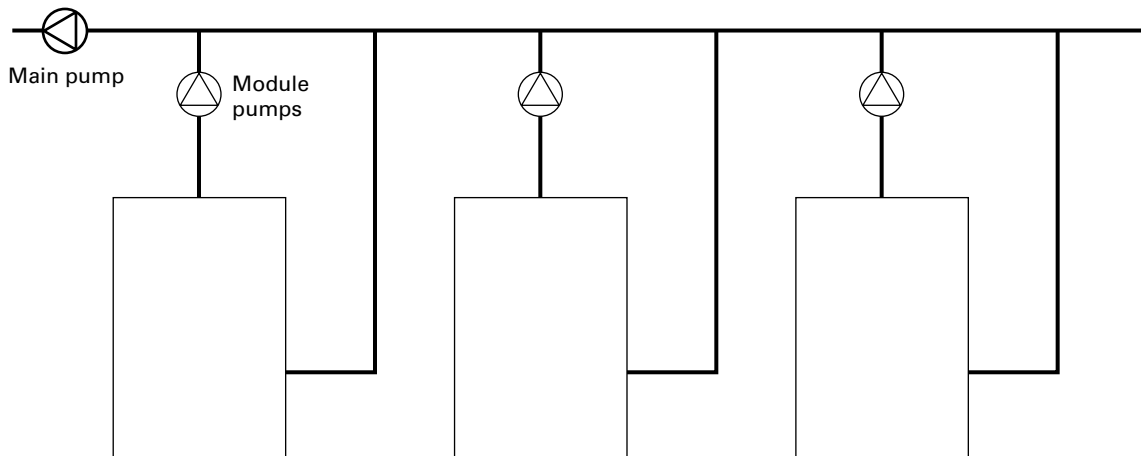

Figure 5.9.8-2 Modules Connected With Primary-Secondary Piping



- (7) drain valve
- (c) Each module of a hot water heating boiler shall be equipped with
 - (1) pressure/altitude gauge
 - (2) thermometer
 - (3) operating temperature control
 - (4) safety relief valve
 - (5) drain valve

5.9.8.2 Assembled Modular Boilers

- (a) The individual modules shall be manifolded together at the job site without any intervening valves. The header or manifold piping is field piping and is exempt from Section IV requirements.
- (b) The assembled modular steam heating boiler shall also be equipped with
 - (1) feedwater connection
 - (2) return pipe connection
 - (3) safety limit control

- (c) The assembled modular hot water heating boiler shall also be equipped with
 - (1) makeup water connection
 - (2) provision for thermal expansion
 - (3) stop valves
 - (4) high-temperature limit control
 - (5) low-water fuel cutoff

5.10 SAFETY

Safety is very important to boiler operation and it should be foremost in the minds of those who are assigned to operate and maintain heating systems. Only properly trained and qualified personnel should work on or operate mechanical equipment; adequate supervision should be provided.

5.11 HOUSEKEEPING

Generally, a neat boiler room indicates a well-run plant. The boiler room should be kept free of all material and equipment not necessary to the operation of the heating system. Good housekeeping should be encouraged, and procedures should include routine examinations to maintain the desired level of cleanliness.

5.12 POSTING OF CERTIFICATES AND/OR LICENSES

Some states and municipalities require licensing or certification of personnel who operate or maintain heating equipment. Also, some authorities require posting of inspection certificates in the boiler room. The supervisor in charge of a given installation should ensure such requirements are met.

5.13 RECORD KEEPING, LOGS, ETC.

5.13.1 Drawings, Diagrams, Instruction Books, Etc.

All drawings, wiring diagrams, schematic arrangements, Manufacturers' descriptive literature and spare parts lists, and written operating instructions should be kept permanently in the boiler room or other suitable location so they will be available to those who operate and maintain the boiler. Where space permits, drawings and

diagrams should be framed or sealed in plastic and hung adjacent to the related equipment. Other material should be assembled and enclosed in a suitable binder. When changes or additions are made, the data and drawings should be revised accordingly.

5.13.2 Logbook

A permanent logbook should be provided in each boiler room to record maintenance work, inspections, examinations, certain tests, and other pertinent data. Brief details of repairs or other work done on a boiler plant (including time started, time completed, and signature of person in charge) should be recorded. Performance and results of tests, inspections, or other routines required by codes or laws, insurance company inspection reports, and initial acceptance test data should be recorded.

5.13.3 Maintenance Schedules and Records

A suggested chart-type log for scheduling and recording work performed on maintenance, testing, and examination during a 1-yr period is shown in [Mandatory Appendix I, Figures I-1-1 and I-1-2](#). The routine work normally performed on heating boilers is listed. As each portion of the work is completed, the person performing the work should date and initial the log in the appropriate space.

ARTICLE 6

OVERPRESSURE PROTECTION

6.1 PRESSURE RELIEF VALVES

6.1.1 General

Pressure relief valves are used to relieve excessive pressure generated within a boiler. The pressure relief valve (or valves) is the final line of protection against overpressure in the boiler. They discharge a volume of steam and hot water when relieving (see 6.4). This is the single most important safety device on any boiler. These valves shall bear the Certification Mark, as illustrated in Figure 6.1.1-1, with HV or V designator to signify compliance with Section IV, HG-402.

6.1.2 Safety Valves

A safety valve is an automatic pressure-relieving device actuated by the pressure generated within the boiler and characterized by full-opening pop action. It is used for steam service. Valves are of the spring-loaded pop type and are factory set and sealed. See Figure 6.1.2-1.

6.1.3 Safety Relief Valves

A safety relief valve is an automatic pressure-relieving device actuated by the pressure generated within the boiler. It is used primarily on water boilers. Valves of this type are spring loaded without full-opening pop action and have a factory-set, nonadjustable pressure setting. See Figure 6.1.3-1.

6.1.4 Temperature and Pressure Safety Relief Valves

A temperature and pressure safety relief valve is a safety relief valve, as described in 6.1.3, that also incorporates a thermal-sensing relief element that is actuated by the upstream water temperature.

Figure 6.1.1-1 Official Certification Mark



6.2 PRESSURE RELIEF VALVE REQUIREMENTS

6.2.1 Safety Valve Requirements for Steam Boilers

6.2.1.1 Each steam boiler shall have one or more officially rated safety valves, identified with the Certification Mark with HV or V designator, of the spring pop type adjusted and sealed to discharge at a pressure not to exceed 15 psi (100 kPa).

6.2.1.2 No safety valve for a steam boiler shall be smaller than NPS $\frac{1}{2}$ (DN 15).

No safety valve shall be larger than NPS 4 (DN 100). The inlet opening shall have an inside diameter equal to or greater than the seat diameter.

6.2.1.3 The minimum relieving capacity of a valve or valves shall be governed by the capacity marking on the boiler called for in Section IV, HG-530.

6.2.1.4 The minimum valve capacity in pounds per hour (kilograms per hour) shall be determined by dividing the maximum output in British thermal units per hour (kilowatts) at the boiler nozzle, obtained by the firing of any fuel for which the unit is installed, by 1,000 (0.646).

6.2.1.5 The safety valve capacity for each steam boiler shall be such that with the fuel-burning equipment installed and operated at maximum capacity, the pressure cannot rise more than 5 psi (35 kPa) above the maximum allowable working pressure.

6.2.1.6 When operating conditions are changed, or additional boiler heating surface is installed, the valve capacity shall be increased, if necessary, to meet the new conditions and to be in accordance with 6.2.1.5. The additional valves required, on account of changed conditions, may be installed on the outlet piping, provided there is no intervening valve.

6.2.2 Safety Relief Valve Requirements for Hot Water Boilers

6.2.2.1 Each hot water heating or supply boiler shall have at least one officially rated safety relief valve that is of the automatic reseating type, identified with the Certification Mark with HV or V designator, and set to relieve at or below the maximum allowable working pressure of the boiler.

Figure 6.1.2-1 Safety Valve

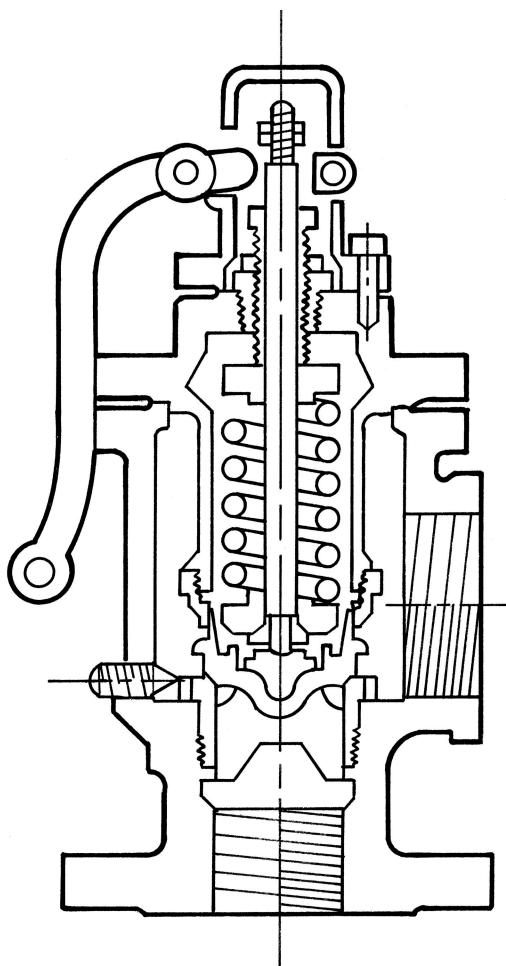

6.2.2.2 Hot water heating or supply boilers limited to a water temperature not in excess of 210°F (99°C) may have, in lieu of the valve(s) specified in 6.2.2.1, one or more officially rated temperature and pressure safety relief valves that is of the automatic reseating type, identified with the Certification Mark with HV designator, and set to relieve at or below the maximum allowable working pressure of the boiler.

6.2.2.3 When more than one safety relief valve is used on either hot water heating or hot water supply boilers, the additional valves shall be officially rated and may have a set pressure within a range not to exceed 6 psi (40 kPa) above the maximum allowable working pressure of the boiler up to and including 60 psi (400 kPa), and 5% for those boilers having a maximum allowable working pressure exceeding 60 psi (400 kPa).

6.2.2.4 No safety relief valve shall be smaller than NPS $\frac{3}{4}$ (DN 20) nor larger than NPS $4\frac{1}{2}$ (DN 115) except that boilers having a heat input not greater

Figure 6.1.3-1 Safety Relief Valve

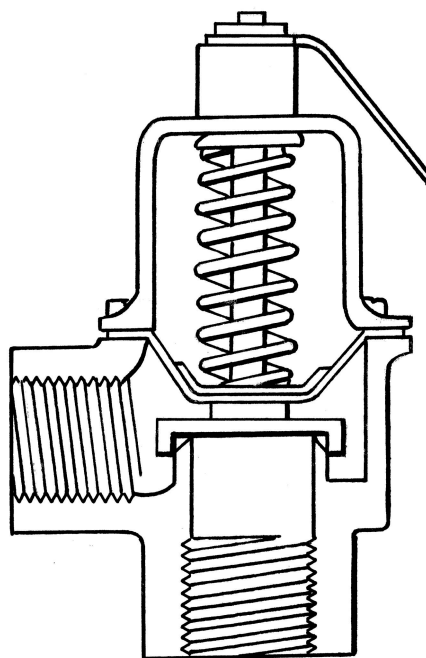

than 15,000 Btu/hr (4.4 kW) may be equipped with a rated safety relief valve of NPS $\frac{1}{2}$ (DN 15).

6.2.2.5 The required relieving capacity in British thermal units per hour of the safety relief valve shall be not less than the maximum allowable input for a water heater or the minimum relieving capacity in pounds per hour (kilograms per hour) on the nameplate of the boiler. If the marking on the safety relief valve is in pounds per hour (kilograms per hour), determine the British thermal units per hour by multiplying by 1,000 (0.646). The relieving capacity for electric water heaters and electric water boilers shall be 3,500 Btu/hr (1.0 kW) per kilowatt of input.

6.3 MOUNTING

6.3.1 General

Pressure relief valves shall be located in the top or side of the boiler. The top or side of the boiler means the highest practicable part of the boiler proper, but in no case shall the safety valve be located on the boiler below the normal operating level, and in no case shall the safety relief valve be located below the lowest permissible water level. Pressure relief valves shall be connected directly to a tapped or flanged opening in the boiler, to a fitting connected to the boiler by a short nipple, to a Y-base, or to a valveless header connecting steam or water outlets on the same boiler. Coil- or header-type boilers shall have the pressure relief valve located on the steam or hot water outlet end.

Pressure relief valves shall be installed with their spindles vertical. The opening or connection between the boiler and any pressure relief valve shall have at least an area equal to the nominal inside area of a Schedule 80 pipe (as defined by ASME B36.10M) of the same nominal pipe size as the inlet of the valve.

6.3.2 Requirements for Common Connections for Two or More Valves

6.3.2.1 When a boiler is fitted with two or more safety valves on one connection, this connection shall have a cross-sectional area not less than the combined areas of inlet connections of all the safety valves with which it connects.

6.3.2.2 When a Y-base is used, the inlet area shall be not less than the combined outlet areas.

When the size of the boiler requires a safety valve or safety relief valve larger than NPS 4½ (DN 115), two or more valves having the required combined capacity shall be used. When two or more valves are used on a boiler, they may be single, directly attached, or mounted on a Y-base.

6.3.3 Threaded Connections

A threaded connection may be used for attaching a valve.

6.3.4 Prohibited Mountings

Pressure relief valves shall not be connected to an internal pipe in the boiler.

6.3.5 Shutoff Valves

Use of shutoff valves is prohibited. No shutoff of any description shall be placed between the pressure relief valve and the boiler, or on discharge pipes between such valves and the atmosphere.

6.4 PRESSURE RELIEF VALVE DISCHARGE PIPING

6.4.1 Discharge Piping

A discharge pipe shall be used. Its internal cross-sectional area shall be not less than the full area of the valve outlet or of the total of the valve outlets discharging thereinto and shall be as short and straight as possible and so arranged as to avoid undue stress on the valve or valves. A union may be installed in the discharge piping close to the valve outlet (see [Figure 6.4.1-1](#)). When an elbow is placed on a safety or safety relief valve discharge pipe, it shall be located close to the valve outlet downstream of the union.

6.4.2 Piping Arrangement

The discharge from pressure relief valves shall be so arranged as to minimize the danger of scalding attendants. The pressure relief valve discharge shall be piped away from the boiler to a safe point of discharge, and there shall be provisions made for properly draining the piping (see [Figure 6.4.1-1](#)). The size and arrangement of discharge piping shall be independent of other discharge piping and such that any pressure that may exist or develop will not reduce the relieving capacity of the relieving devices below that required to protect the boiler.

6.5 TEMPERATURE AND PRESSURE SAFETY RELIEF VALVES

Hot water heating or supply boilers limited to a water temperature of 210°F (99°C) may have one or more officially rated temperature and pressure safety relief valves installed. The requirements of [6.1](#) through [6.4](#) shall be met, except as follows:

- (a) A Y-type fitting shall not be used.
- (b) If additional valves are used, they shall be temperature and pressure safety relief valves.
- (c) When the temperature and pressure safety relief valve is mounted directly on the boiler with no more than 4 in. (100 mm) maximum interconnecting piping, the valve may be installed in the horizontal position with the outlet pointed down.

6.6 VALVE REPLACEMENT

Safety valves and safety relief valves requiring repairs shall be replaced with a new valve or repaired by the manufacturer.

6.7 TRY-LEVER TEST FOR SAFETY VALVES (STEAM BOILERS)

(a) *Prior to Test.* As precautionary measures, all personnel concerned with conducting a safety valve test should be briefed on the location of all shutdown controls to be used in the event of an emergency, and there should be at least two people present during the test. Care should be taken to protect those present from escaping steam.

(b) *Frequency of Test.* A try-lever test of the safety valve should be performed every 30 days that the boiler is in operation or after any period of inactivity.

(c) *Procedure*

Step 1. With the boiler under a minimum of 5 psi (35 kPa) pressure, lift the try lever on the safety valve to the wide-open position and allow steam to be discharged for 5 sec to 10 sec.

Step 2. Release the try lever and allow the spring to snap the disk to the closed position.

(a) If the valve simmers, operate the try lever two or three times to allow the disk to seat properly.

Figure 6.4.1-1 Safety Relief Valve Discharge Pipe

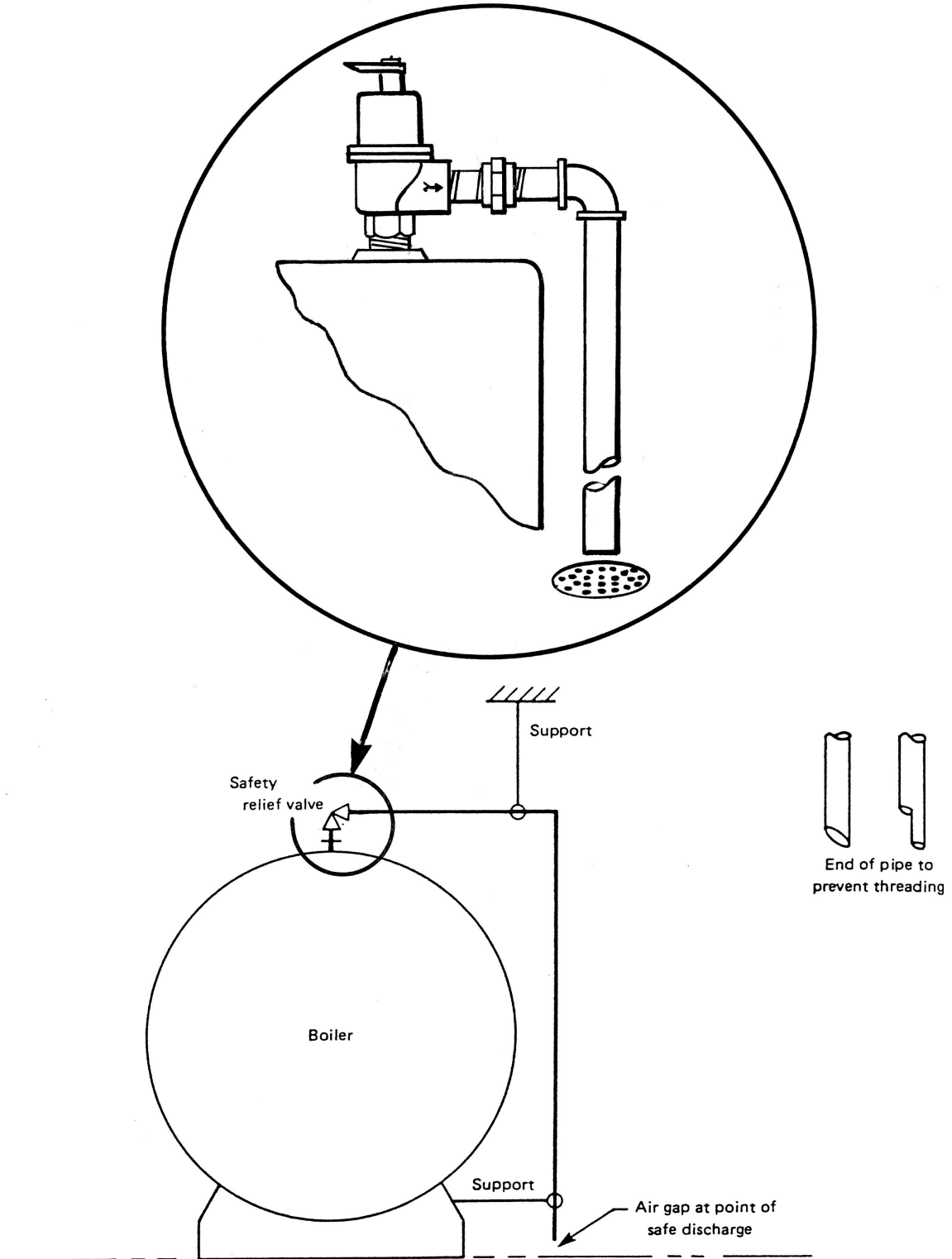

(b) If the valve continues to simmer, it must be replaced or repaired by an authorized representative of the safety valve manufacturer.

Step 3. Examine the valve for evidence of scale or encrustation within the body. Do not disassemble the valve or attempt to adjust the spring setting.

Step 4. Enter the date of this test into the boiler logbook.

It is advisable to have a chain attached to the try lever of the valve to facilitate this test and allow it to be conducted in a safe manner from the floor.

6.8 TRY-LEVER TEST FOR SAFETY RELIEF VALVES (WATER BOILERS)

(a) *Frequency of Test.* A try-lever test of the safety relief valve should be conducted every 30 days during the heating season, after any prolonged period of inactivity, and prior to the annual safety relief valve test.

(b) *Procedure*

Step 1. Check the safety relief valve discharge piping to determine that it is properly installed and supported.

Step 2. Check and log the system operating pressure and temperature.

Step 3. Lift the try lever on the safety relief valve to the full-open position and hold it for at least 5 sec or until clean water is discharged.

Step 4. Release the try lever and allow the spring to snap to the closed position.

(a) If the valve leaks, operate the try lever two or three times to clear the seat of any foreign matter preventing proper seating. As safety relief valves are normally piped to the floor or near a floor drain, it may take some time to determine if the valve has shut completely.

(b) If the safety relief valve continues to leak, it must be replaced before the boiler is returned to operation.

Step 5. Check that system operating pressure and temperature have returned to normal.

Step 6. Check again to ensure the safety relief valve has closed completely and is not leaking.

ARTICLE 7 SYSTEM ACCESSORIES

7.1 STEAM BOILERS

7.1.1 Steam Trap

A steam trap is a device put on steam lines and on the outlet of heating units to permit the exit of air and condensate but to prevent the passage of steam. The types of steam traps in common use are thermostatic, float, combination float and thermostatic, and bucket. See [Figures 7.1.1-1 through 7.1.1-4](#).

7.1.2 Condensate Return Pump Loops

7.1.2.1 Condensate return pumps are used on either one- or two-pipe steam systems to return condensate to the boiler where this cannot be done by gravity. They are generally used in conjunction with a reservoir (condensate return tank) and a float-operated switch for starting the pump motor.

7.1.2.2 Where two boilers are connected together and served from one condensate return pump, a vacuum breaker may be required on the idle boiler to prevent the formation of a vacuum that will affect the functioning of the feed valve.

7.1.2.3 The return pipe connections of each boiler supplying a gravity return of a steam heating system should be so arranged as to form a loop similar to that shown in [Figure 7.1.2.3-1](#) so that the water in each boiler cannot be forced below the safe water level. The

loop is required in gravity systems and may be included in pump return systems.

7.1.2.4 Pumped feedwater returns, when connected to a return loop, should be connected directly to the lower boiler connection of the loop because under some circumstances a connection to the return loop near the boiler waterline may cause objectionable noise or water hammer.

7.1.3 Vacuum Return Pump

The vacuum return pump is used in larger steam systems to create a partial vacuum in the return lines of the heating system and thus assist in the return of the condensate, elimination of air, and equal distribution of steam.

7.1.4 Economizer (Steam Boiler)

An economizer is a heat exchanger in which feedwater to be supplied to a boiler is heated by flue gases exiting the boiler. When such an economizer is supplied with a Section IV boiler, it falls within the scope of Section IV rules. The economizer may be constructed in accordance with rules of either Section IV or Section VIII, Division 1.

Figure 7.1.1-1 Thermostatic Trap

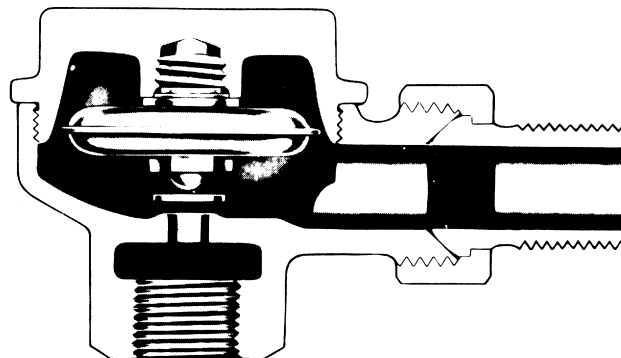

Figure 7.1.1-2 Float Trap

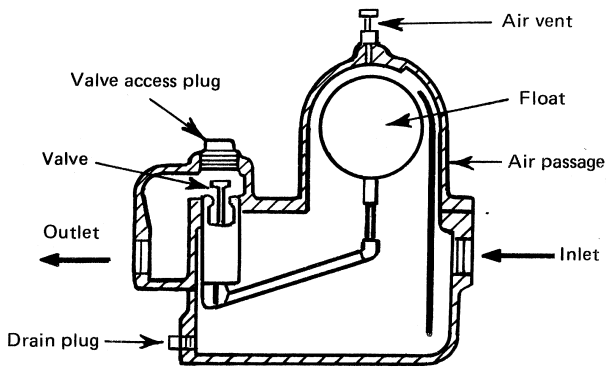

Figure 7.1.1-4 Bucket Trap With Trap Closed

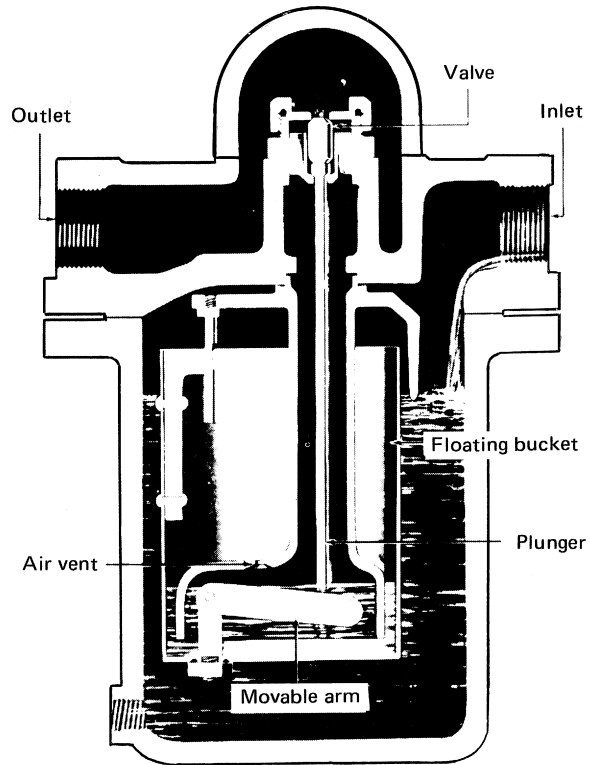
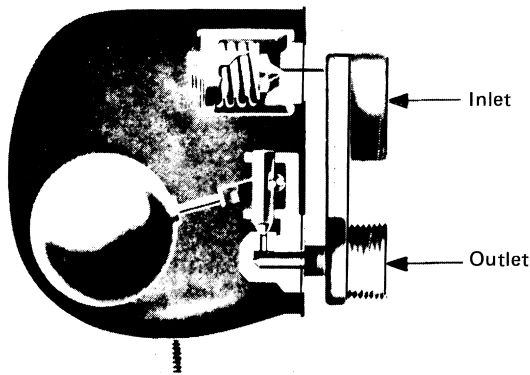

Figure 7.1.1-3 Float and Thermostatic Trap



Section IV boiler or water heater, it falls within the scope of Section IV rules. The economizer may be constructed in accordance with the rules of either Section IV or Section VIII, Division 1.

7.2 HOT WATER BOILERS

7.2.1 Air Eliminators

Air eliminators are sometimes installed on hot water boilers to eliminate air from the system as it is released from the water within the boiler.

7.2.2 Circulators (Circulating Pumps)

Circulators are basically centrifugal pump units used on hot water heating systems to force the flow of water through the system.

7.2.3 Economizer (Hot Water Boiler or Potable Water Heater)

An economizer is a heat exchanger in which return water to be supplied to a boiler or water heater is heated by flue gases exiting the boiler or water heater. When such an economizer is supplied with an ASME

7.2.4 Expansion Tank

Expansion tanks are used on hot water systems to allow for the expansion of the water when it is heated. A gas cushion in the tank allows for the expansion or contraction of the water as it is heated or cooled. All hot water heating systems incorporating hot water tanks or fluid relief columns shall be so installed as to prevent freezing.

7.2.4.1 Systems With Open Expansion Tank. If the system is equipped with an open expansion tank, an indoor overflow from the upper portion of the expansion tank shall be provided in addition to an open vent. The indoor overflow should be carried within the building to a suitable plumbing fixture or the basement.

7.2.4.2 Closed-Type Systems. If the system is of the closed type, an airtight tank or other suitable gas cushion shall be installed that will be consistent with the volume and capacity of the system, and it shall be suitably designed for a hydrostatic test pressure of $2\frac{1}{2}$

Figure 7.1.2.3-1 Typical Return Loop

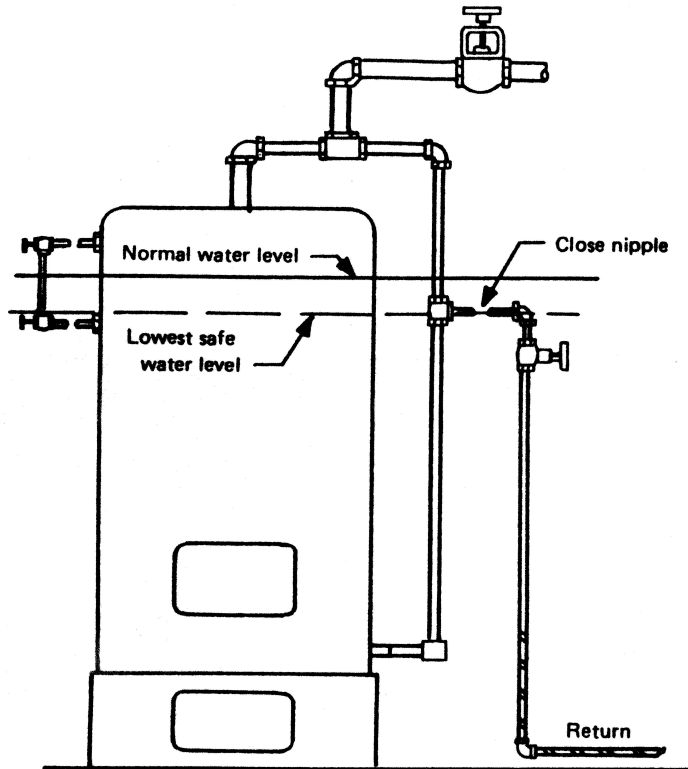

times the allowable working pressure of the system. Expansion tanks for systems designed to operate above 30 psi (200 kPa) shall be constructed in accordance with Section VIII, Division 1. Provisions shall be made for draining the tank without emptying the system, except for pre-pressurized tanks.

7.2.4.3 Minimum Capacity of Closed-Type Tank. The minimum capacity of the closed-type expansion tank may be determined from the following equation:

(U.S. Customary Units)

$$V_t = \frac{(0.00041T - 0.0466)V_s}{(P_a/P_f) - (P_a/P_o)}$$

(SI Units)

$$V_t = \frac{(0.000738T - 0.03348)V_s}{(P_a/P_f) - (P_a/P_o)}$$

where

- P_a = atmospheric pressure
- P_f = fill pressure
- P_o = maximum operating pressure
- T = average operating temperature
- V_s = volume of system, not including tanks
- V_t = minimum volume of tanks

7.2.5 Storage Tanks for Hot Water Supply Systems

If a system is to utilize a storage tank that exceeds a nominal water-containing capacity of 120 gal (454 L), the tank shall be constructed in accordance with the rules of Section IV, Part HLW; Section VIII, Division 1; or Section X. For tanks constructed to Section X, the maximum allowable temperature marked on the tank shall equal or exceed the maximum water temperature marked on the boiler.

ARTICLE 8

CONTROLS AND INSTRUMENTATION

8.1 LOW-WATER FUEL CUTOFFS AND WATER FEEDERS

Low-water fuel cutoffs are designed to provide protection against hazardous low-water conditions in heating boilers. Records indicate that many boiler failures result from low-water conditions. Low-water fuel cutoffs may be divided into two general types, float and probe.

8.1.1 Float-Type Low-Water Fuel Cutoffs

Float-type low-water fuel cutoffs may be in combination with a water feeder or constructed as a separate unit. The combination feeder-cutoff units are generally used on steam boilers while the cutoff units are sometimes installed as the sole cutoff on hot water boilers or as a second cutoff on steam boilers. A feeder-cutoff combination adds water as needed to maintain a minimum water level and stops the firing device if the water level falls to the lowest permissible level. Both operations are accomplished by the movement of the float that is linked to the

water valve or pump control and burner cutoff switch. The units that serve as fuel cutoffs only are basically the same as the combination unit but without the water feeder valve (see [Figure 8.1.1-1](#)). A water feeder installation normally acts as an operating device to maintain a predetermined safe water level in the boiler.

8.1.2 Electric-Probe-Type Low-Water Fuel Cutoffs

Electric-probe-type low-water fuel cutoffs may be contained in a water column mounted externally on the boiler or may be mounted on the boiler shell. Some consist of two electrodes (probes) that under normal conditions are immersed in the boiler water with a small current being conducted from one electrode to the other to energize a relay. Others use one probe, and the boiler shell, in effect, becomes the other probe. If the water level drops sufficiently to uncover the probes, the current flow stops and the relay operates to shut off the burner. See [Figure 8.1.2-1](#).

Figure 8.1.1-1 Float-Type Low-Water Cutoff

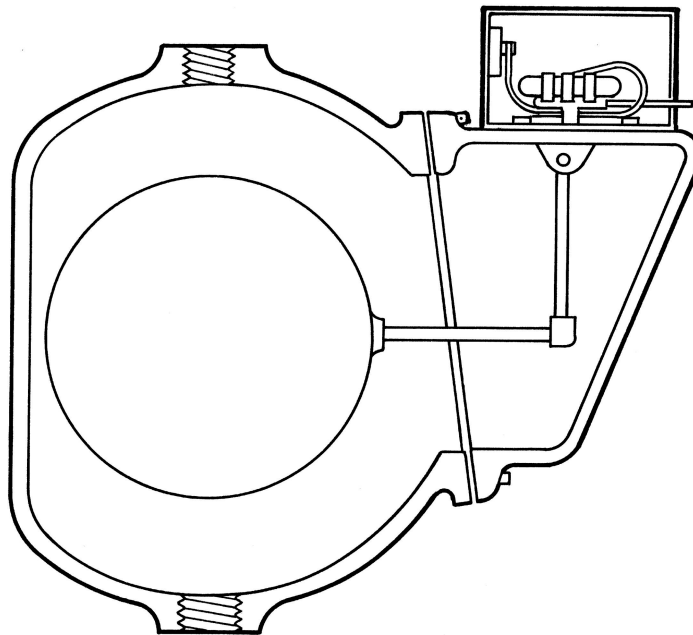
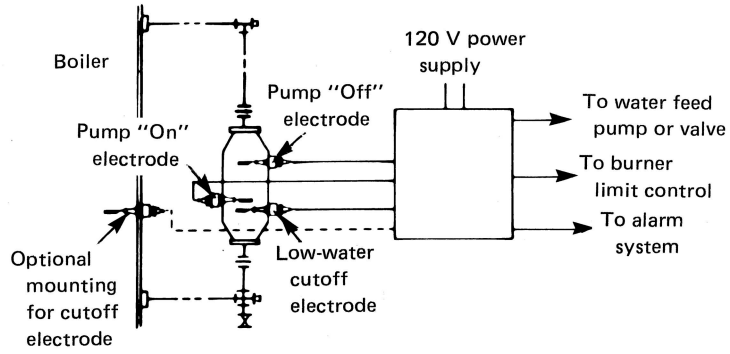
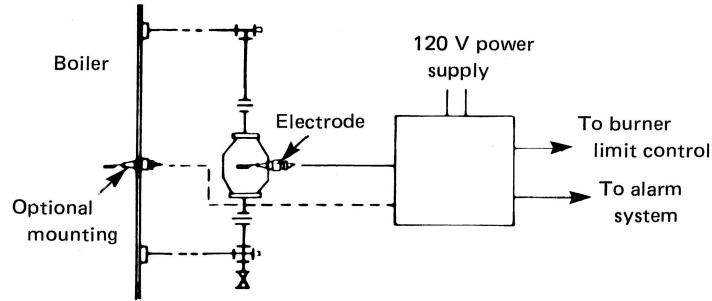

Figure 8.1.2-1 Probe-Type Low-Water Cutoff



Automatic Boiler Water Feed and Low-Water Cutoff – For Steam



Low-Water Cutoff – For Steam

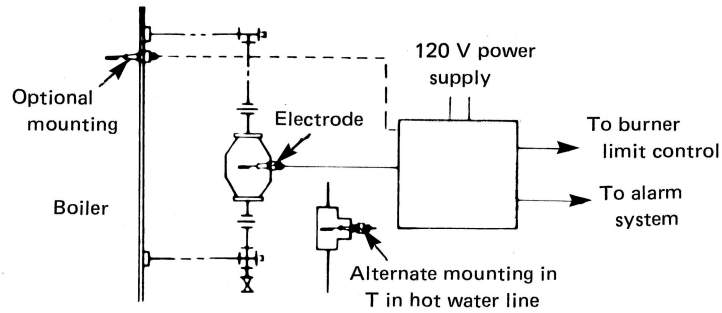

Low-Water Cutoff – For Hot Water

8.2 PRESSURE GAUGE

8.2.1 General

Each steam boiler shall have a steam gauge or a compound steam gauge connected to its steam space, water column, or steam connection. Each hot water heating or hot water supply boiler should have a pressure gauge connected to it or to its flow connection in such a manner that the point of connection cannot be shut off from the boiler.

8.2.2 Mounting

On a steam boiler, a siphon tube (pigtail) is required to protect the gauge from steam. A cock should be provided, placed on the pipe near the gauge, to facilitate servicing of the gauge. Piping or tubing for pressure gauge connections shall be of nonferrous metal when smaller than NPS 1 (DN 25). The handle of the cock shall be parallel to the pipe in which it is located when the cock is open.

8.2.3 Types of Pressure Gauges

Pressure gauges may be either mechanical or electronic.

(a) *Mechanical Gauges (Analog)*. The scale on a water boiler pressure gauge should be graduated to not less than 1½ times nor more than 3½ times the pressure at which the safety relief valve is set. The scale on the dial of a steam boiler pressure gauge should be graduated to not less than 30 psi (200 kPa) nor more than 60 psi (414 kPa).

(b) *Electronic Gauges*. Electronic gauges should

(1) be powered from the boiler power supply, have a backup power supply, and have a display that remains on at all times

(2) have a full-scale range of 1½ times the safety relief valve pressure setting

(3) be accurate to within ±2% of full scale

(4) have a transducer compatible with both liquids and gases and be temperature compensated

(5) have an operating temperature range of 32°F to 250°F (0°C to 120°C) unless otherwise required by the application

8.2.4 Calibration

The gauge used on a boiler should be calibrated at least once per year. This can be accomplished by comparing it to a master-calibrated gauge or using a deadweight tester. If the gauge is damaged or cannot be calibrated to provide consistent readings, it should be discarded and replaced with a new gauge.

8.3 CONTROLS

8.3.1 General

Automatically fired boilers may be equipped with operating, limit, safety, and programming controls that may be electrically or pneumatically operated. The functions of these controls are described in 8.3.4 through 8.3.7.

8.3.2 Spare Parts

Spare parts for controls, including electronic components that require time for procurement, should be maintained in stock supply.

8.3.3 Power for Electrically Operated Controls

All controls should be powered with a potential of 150 V or lower with one side grounded. A separate equipment ground conductor should be brought to the control panel frame with ground continuity ensured to the fuel valve. All operating coils of control devices should be connected to the neutral side of the control circuit, and all control limit switches or contacts should be in the ungrounded (hot) side of the control circuit. If an isolating transformer is used, it should be bonded to the control panel frame. The equipment ground is not required when the isolating transformer is used. Do not fuse control transformers above their rated current value because these devices are current limiting and an oversize fuse may not blow under short-circuit conditions.

8.3.4 Operating Controls

The operating controls shall

(a) start, stop, and modulate the burner (if desired) in response to the system's demand, keeping steam pressure or hot water temperature at or below the limit control setting

(b) maintain proper water level in steam boilers

(c) maintain proper water pressure in hot water heating boilers

8.3.5 Limit Controls

The limit controls shall stop the burner

(a) when the steam pressure exceeds 15 psi (100 kPa) for steam boilers

(b) when the water temperature exceeds 250°F (120°C) for hot water boilers

(c) when the water level drops below the minimum permissible level

(d) when required in the event of unusual conditions such as

(1) high stack temperature

(2) high or low gas-fuel pressure

(3) high or low fuel-oil temperature

8.3.6 Safety Controls

The safety controls shall

- (a) stop fuel flow in case of ignition failure
- (b) stop fuel flow in case of main flame interruption
- (c) stop fuel flow in case of mechanical draft failure
- (d) stop fuel flow in case of circuit failure
- (e) stop fuel flow and cause lockout in case of high or low gas pressure, when the boiler is so equipped

8.3.7 Programming Controls

Programming controls, when used, provide proper sequencing of the operating, limit, and safety controls to ensure that all conditions necessary for proper burner operation are satisfied. Included in a programmed control are prepurge and postpurge cycles to remove accumulated gases.

8.4 STEAM HEATING BOILERS

8.4.1 Low-Water Fuel Cutoffs

8.4.1.1 Requirements for the type and number of low-water fuel cutoffs are dictated by local codes, NBIC, ASME CSD-1, and/or NFPA 85, depending on the input and boiler design. Each automatically fired steam boiler is equipped with at least one automatic low-water fuel cutoff that automatically cuts off the fuel supply before the surface of the water falls to the lowest visible part of the water gauge glass. If the water-feeding device is installed, it shall be so constructed that the water inlet valve cannot feed water into the boiler through the float chamber and so located as to supply requisite feedwater.

8.4.1.2 A low-water fuel cutoff or water-feeding device may be attached directly to a boiler. A fuel cutoff or water-feeding device may also be installed in the tapped openings available for attaching a water glass directly to a boiler, provided the connections are made to the boiler with nonferrous tees or Ys not less than NPS $\frac{1}{2}$ (DN 15) between the boiler and the water glass so that the water glass is attached directly and as close as possible to the boiler; the run of the tee or Y shall take the water glass fittings, and the side outlet or branch of the tee or Y shall take the fuel cutoff or water-feeding device. The ends of all nipples shall be reamed to full-size diameter.

8.4.1.3 Fuel cutoffs and water-feeding devices embodying a separate chamber shall have a vertical drain pipe and a blowoff valve not less than NPS $\frac{3}{4}$ (DN 20), located at the lowest point in the water-equalizing pipe connections so that the chamber and the equalizing pipe can be flushed and the device tested.

8.4.1.4 ASME CSD-1 requires two low-water cutoffs on steam boilers. Refer to ASME CSD-1 for applicable requirements.

8.4.2 Steam Gauges

8.4.2.1 Each steam boiler shall have a steam gauge or a compound steam gauge connected to its steam space, water column, or steam connection. The gauge or piping to the gauge shall contain a siphon or equivalent device that will develop and maintain a water seal that will prevent steam from entering the gauge tube. The piping shall be so arranged that the gauge cannot be shut off from the boiler except by a cock placed in the pipe at the gauge and provided with a tee or lever handle arranged to be parallel to the pipe in which it is located when the cock is open. The gauge connection boiler tapping, external siphon, or piping to the boiler shall be not less than NPS $\frac{1}{4}$ (DN 8). Where steel or wrought iron pipe or tubing is used, the boiler connection and external siphon shall be not less than NPS $\frac{1}{2}$ (DN 15). Ferrous and nonferrous tubing having inside diameters at least equal to that of nominal pipe sizes listed above may be substituted for pipe.

8.4.2.2 The scale on the dial of the steam boiler gauge shall be graduated to not less than 30 psi (200 kPa) nor more than 60 psi (400 kPa). The travel of the pointer from 0 psi to 30 psi (0 kPa to 200 kPa) pressure shall be at least 3 in. (75 mm).

8.4.3 Water Gauge Glasses

8.4.3.1 Each steam boiler shall have one or more water gauge glasses attached to the water column or boiler by means of valved fittings not less than NPS $\frac{1}{2}$ (DN 15), with the lower fitting provided with a drain valve of a type having an unrestricted drain opening not less than $\frac{1}{4}$ in. (6 mm) in diameter to facilitate cleaning. Gauge glass replacement shall be possible with the boiler under pressure. Water glass fittings may be attached directly to a boiler. Boilers having an internal vertical height of less than 10 in. (254 mm) may be equipped with a water-level indicator of the glass bull's-eye type, provided the indicator is of sufficient size to show the water at both normal operating and low-water cutoff levels.

8.4.3.2 Transparent material other than glass may be used for the water gauge, provided the material remains transparent and has proved suitable for the pressure, temperature, and corrosive conditions expected in service.

8.4.3.3 The lowest visible part of the water gauge glass shall be at least 1 in. (25 mm) above the lowest permissible water level recommended by the boiler Manufacturer. With the boiler operating at this lowest permissible water level, there shall be no danger of overheating any part of the boiler.

8.4.3.4 In electric boilers of the submerged electrode type, the water gauge glass shall be so located to indicate the water levels both at startup and under maximum steam load conditions as established by the Manufacturer.

8.4.3.5 In electric boilers of the resistance heating element type, the lowest visible part of the water gauge glass shall not be below the top of the electric resistance heating element. Each boiler of this type shall also be equipped with an automatic low-water electrical power cutoff so located as to automatically cut off the power supply to the heating elements before the surface of the water falls below the top of the electrical resistance heating elements.

8.4.3.6 A water-level indicator using an indirect sensing method may be used in lieu of an operating water gauge glass; however, a water gauge glass must be installed and operable but may be shut off by valving. The water-level indicator may be attached to a water column or directly to the boiler by means of valved fittings not less than NPS $\frac{1}{2}$ (DN 15). The device shall be provided with a drain valve of a type having an unrestricted drain opening not less than $\frac{1}{4}$ in. (6 mm) in diameter to facilitate cleaning.

8.4.4 Water Column and Water-Level-Control Pipes

8.4.4.1 The minimum size of ferrous or nonferrous pipes connecting a water column to a steam boiler shall be NPS 1 (DN 25). No outlet connections, except for damper regulator, feedwater regulator, steam gauges, or apparatus that does not permit the escape of any steam or water except for manually operated blow-downs, shall be attached to the water column or the pipe connecting a water column to a boiler. If the water column, gauge glass, low-water fuel cutoff, or other water-level-control device is connected to the boiler by pipe and fittings, no shutoff valves of any type shall be placed in such pipe, and a cross or equivalent fitting to which a drain valve and piping may be attached shall be placed in the water piping connection at every right turn to facilitate cleaning. The water column drain pipe and valve shall be not less than NPS $\frac{3}{4}$ (DN 20).

8.4.4.2 The steam connections to the water column of a horizontal firetube wrought boiler shall be taken from the top of the shell or the upper part of the head, and the water connection shall be taken from a point not above the centerline of the shell. For a cast iron boiler, the steam connection to the water column shall be taken from the top end of the steam header, and the water connection shall be made on an end section not less than 6 in. (150 mm) below the bottom connection to the water gauge glass.

8.4.5 Pressure Controls

8.4.5.1 Each automatically fired steam boiler shall be protected from overpressure by two pressure-operated controls.

8.4.5.2 Each automatically fired steam boiler or assembled modular steam boiler shall have a safety limit control that will cut off the fuel supply to prevent steam pressure from exceeding the 15-psi (100-kPa) maximum allowable working pressure of the boiler. Each control shall be constructed to prevent a pressure setting above 15 psi (100 kPa).

8.4.5.3 Each individual steam boiler shall have a control that will cut off the fuel supply when the pressure reaches an operating limit, which shall be less than the maximum allowable pressure.

8.4.5.4 Shutoff valves of any type shall not be placed in the steam pressure connection between the boiler and the controls described in 8.4.5.1 through 8.4.5.3. These controls shall be protected with a siphon or equivalent means of maintaining a water seal that will prevent steam from entering the control.

8.4.5.5 ASME CSD-1 requires that operation of the pressure control described in 8.4.5 shall cause a safety shutdown requiring a manual reset.

8.5 HOT WATER HEATING BOILERS

8.5.1 Low-Water Fuel Cutoff (Hot Water)

8.5.1.1 Each automatically fired hot water heating boiler with heat input greater than 400,000 Btu/hr (117 kW) shall have an automatic low-water fuel cutoff that has been designed for hot water service, and it shall be so located as to automatically cut off the fuel supply when the surface of the water falls to the level established in 8.5.1.2.

8.5.1.2 As there is no normal waterline to be maintained in a hot water heating boiler, any location of the low-water fuel cutoff above the lowest safe permissible water level established by the boiler Manufacturer is satisfactory.

8.5.1.3 A coil-type boiler or a watertube boiler with heat input greater than 400,000 Btu/hr (117 kW) requiring forced circulation to prevent overheating of the coils or tubes shall have a flow-sensing device installed in the outlet piping in lieu of the low-water fuel cutoff required in 8.5.1.1 to automatically cut off the fuel supply when the circulating flow is interrupted.

8.5.1.4 A means should be provided for testing the operation of the external low-water fuel cutoff without resorting to draining the entire system. Such means should not render the device inoperable except as

described as follows. If the means temporarily isolates the device from the boiler during this testing, it shall automatically return to its normal position. The connection may be so arranged that the device cannot be shut off from the boiler except by a cock placed at the device and provided with a tee or level handle arranged to be parallel to the pipe in which it is located when the cock is open.

8.5.1.5 ASME CSD-1 requires that operation of the low-water cutoff on a hot water boiler shall cause a safety shutdown requiring manual reset.

8.5.2 Thermometers

Each hot water heating or hot water supply boiler shall have a thermometer so located and connected that it shall be easily readable. The thermometer shall be so located that it shall at all times indicate the temperature of the water in the boiler at or near the outlet.

(a) The thermometer shall have a minimum reading of 70°F (20°C) or less.

(b) The thermometer shall have a maximum reading at least equal to 320°F (160°C) but not more than 400°F (205°C).

(c) An electronic temperature sensor used in lieu of a thermometer shall meet the following requirements:

(1) The sensor shall be powered from the boiler power supply, and it shall have a display that remains on at all times. The sensor shall have a backup power supply.

(2) The full scale of the sensor and display must be a minimum of 70°F to 320°F (20°C to 160°C). It shall be accurate within $\pm 1^\circ$.

(3) The sensor shall have a minimum operating temperature range of 32°F to 300°F (0°C to 150°C).

(4) The display shall have an ambient operating temperature range of 32°F to 120°F (0°C to 50°C) unless otherwise required by the application.

8.5.3 Pressure or Altitude Gauges

Each hot water heating or hot water supply boiler shall have a pressure or altitude gauge connect to it or its flow connection in such a manner that it cannot be shut off from the boiler except by a cock with a tee or lever handle placed on the pipe near the gauge. The hand of the cock shall be parallel to the pipe in which it is located when the cock is open.

8.5.4 Temperature Controls

Each automatically fired hot water heating or hot water supply boiler shall be protected from overtemperature by two temperature-operated controls. The space thermostat used for comfort control is not considered one of the required temperature-operated controls.

8.5.4.1 Each individually automatically fired hot water heating or hot water supply boiler shall have a high-temperature limit control that will cut off the fuel supply at or below the marked maximum water temperature at the boiler outlet. This control shall be constructed to prevent a temperature setting above the maximum.

8.5.4.2 Each individual hot water heating or hot water supply boiler shall have a control that will cut off the fuel supply when the system water temperature reaches a preset operating limit that shall be less than the maximum water temperature.

8.5.4.3 ASME CSD-1 requires that the operation of the temperature control described in 8.5.4.1 and 8.5.4.2 shall cause a safety shutdown requiring manual reset.

8.5.5 Differential Temperature Controls

Some forced circulation water boilers incorporate differential temperature controls to help protect the boiler from damage caused by inadequate water flow while the boiler is firing. Differential temperature controls are typically operated by the boiler's primary safety control, which receives information from temperature sensors on the inlet and outlet water connections of the boilers. The controls compare the difference in the inlet and outlet water temperature when the burner is firing. If the temperature rise or rate of rise is too large, indicating potential overheating of the boiler heat exchanger, the controls will either reduce the heat input rate or shut off the burner to protect the heat exchanger.

8.5.6 Air for Pneumatically Operated Controls

Determine that compressed air for pneumatically operated controls is clean, dry, and available at adequate pressure.

ARTICLE 9

OPERATION AND MAINTENANCE OF STEAM BOILERS

9.1 STARTING A NEW BOILER AND HEATING SYSTEM

A new boiler should be cleaned and filled as detailed in 9.1.1 through 9.1.5.

9.1.1 Examination for Foreign Objects

Prior to starting a new boiler, an examination should be made to ensure that no foreign matter, such as tools, equipment, and rags, has been left in the boiler.

9.1.2 Checks Before Filling

Before putting water into a new boiler, make certain that the firing equipment is in operating condition to the extent that this is possible without actually lighting a fire in the empty boiler. This is necessary because raw water must be boiled [or heated to at least 180°F (82°C)] promptly after it is introduced into the boiler in order to drive off the dissolved gases that might otherwise corrode the boiler.

9.1.3 Operation to Clean the System

Fill the boiler to the proper waterline and operate the boiler with steam in the entire system for a few days to bring the oil and dirt back from the system to the boiler. This is not necessary if the condensate is to be temporarily wasted to the sewer, in which case the system should be operated until the condensate runs clear.

9.1.4 Boiling Out

The oils and greases that accumulate in a new boiler can usually be washed out by boiling. A qualified chemical water treatment specialist should be consulted for instructions regarding appropriate chemical compounds and concentrations that are compatible with local environmental regulations governing disposal of the boil-out solutions.

Proceed as follows:

Step 1. Fill the boiler to the normal waterline.

Step 2. Remove the plug from the tapping on the highest point on the boiler. If no other opening is available, the safety valve(s) may be removed, in which case the valve must be handled with extreme care to avoid damaging it.

Step 3. Add an appropriate boil-out compound through the prepared opening.

Step 4. Replace the plug or the safety valve(s).

Step 5. Start the firing equipment and check operating, limit, and safety controls. Review Manufacturer's recommendations for boiler and burner startup.

Step 6. Boil the water for at least 5 hr.

Step 7. Stop the firing equipment.

Step 8. Drain the boiler in a manner and to a location that allow the hot water to be discharged safely.

Step 9. Wash the boiler thoroughly using a high-pressure water stream.

Step 10. Fill the boiler to the normal waterline.

Step 11. Add boiler water treatment compound as needed.

Step 12. Promptly boil the water or heat it to at least 180°F (82°C).

The boiler is now ready to be put into service or on standby.

9.1.5 Second Boil-Out for Stubborn Cases

In stubborn cases, the simple boil-out described in 9.1.4 may not remove all the oil and grease and another boil-out using a surface blowoff may be necessary. For this type of cleaning, proceed as follows:

Step 1. Prepare the boiler for cleaning by running a temporary pipeline from the surface blowoff connection to an open drain or some other location where hot water may be discharged safely. If no such tapping is available, use the safety valve tapping, but run the pipe full size and as short a length as possible. Do not install a valve or any other obstruction in this line. Handle the safety valve carefully and protect it against damage while it is out of the boiler.

Step 2. Fill the boiler until water reaches the top of the water gauge glass.

Step 3. Add a boil-out compound.

Step 4. Start the firing equipment and operate sufficiently to boil the water without producing steam pressure.

Step 5. Boil for about 5 hr.

Step 6. Open the boiler feed pipe sufficiently to permit a steady trickle of water to run out the overflow pipe.

Step 7. Continue this slow boiling and trickle of overflow for several hours until the water coming from the overflow is clear.

Step 8. Stop the firing equipment.

Step 9. Drain the boiler in a manner and to a location that allow the hot water to be discharged safely.

Step 10. Remove covers and plugs from all washout openings and wash the water side of the boiler thoroughly using a high-pressure water stream.

Step 11. Refill the boiler until 1 in. (25 mm) of water shows in the gauge glass. If water in the gauge glass does not appear to be clear, repeat [Steps 2](#) through [11](#) and boil out the boiler for a longer time.

Step 12. Remove temporary piping.

Step 13. Add a charge of boiler water treatment compound.

Step 14. Close the boiler.

Step 15. Replace the safety valve.

Step 16. Promptly boil the water or heat it to at least 180°F (82°C).

The boiler is now ready to be put into service or on standby.

9.2 STARTING A BOILER AFTER LAYUP (SINGLE-BOILER INSTALLATION)

9.2.1 Procedure

When starting a boiler after layup, proceed as follows:

Step 1. Review Manufacturer's instructions for startup of the burner and boiler.

Step 2. Set the control switch to the "Off" position.

Step 3. Make sure fresh air to the boiler room is unobstructed.

Step 4. Check availability of fuel.

Step 5. Check the water level in the gauge glass. Make sure the gauge glass valves are open.

Step 6. Use the try cocks, if provided, to double-check the water level.

Step 7. Vent the combustion chamber to remove unburned gases.

Step 8. Clean the glass on the fire scanner, if provided.

Step 9. Set the main steam shutoff valve to the open position.

Step 10. Open the cold water supply valve to the water feeder, if provided. Open suction and discharge valves on vacuum or condensate pumps, and set electrical switches for desired operation. Vent the boiler to remove air when necessary.

Step 11. Check the operating-pressure setting of the boiler.

Step 12. Check the manual reset, if provided, on the low-water fuel cutoff and high-limit pressure control to determine if they are properly set.

Step 13. Set the manual fuel oil supply or manual gas valve to the open position.

Step 14. Place the circuit breaker or fused disconnect switch in the "On" position.

Step 15. Place all boiler emergency switches in the "On" position.

Step 16. Place the boiler control starting switch in the "On" or "Start" position.

CAUTION: Do not stand in front of boiler access or cleanout doors. This is a precautionary measure to protect personnel should a combustion explosion occur.

Step 17. Bring pressure and temperature up slowly. Stand by the boiler until it reaches the established cutout point to make sure the operating control shuts off the burner.

Step 18. During the pressure buildup period, walk around the boiler frequently to observe that all associated equipment and piping are functioning properly.

Step 19. Check for proper over-the-fire draft and breech pressure. Verify and log burner combustion parameters.

Step 20. Immediately after the burner shuts off, examine the water column and open each try cock (if provided) individually to determine the true water level.

Step 21. In the logbook, enter the following:

(a) date and time of startup

(b) any irregularities observed and corrective action taken

(c) time when controls shut off the burner at established pressure, tests performed, etc.

(d) signature of operator

Step 22. Check the safety valve for evidence of simmering. Perform try-lever test.

9.2.2 Action in Case of Abnormal Conditions

If any abnormal conditions occur during light-off or pressure buildup, immediately open the emergency switch and lock out the equipment. (Do not attempt to restart the unit until difficulties have been identified and corrected.)

9.3 CONDENSATION

Following a cold start, condensation (sweating) may occur in a gas-fired boiler to such an extent that it appears that the boiler is leaking. This condensation can be expected to stop after the boiler is hot.

9.4 CUTTING IN AN ADDITIONAL BOILER

When placing a boiler on the line with other boilers that are already in service, first start the boiler using the procedures in [9.1](#) and [9.2](#) but have its supply stop valve and the return stop valve closed. If one is provided, open the drain valve between the stop valve at the boiler outlet and the steam main. When the pressure within the boiler is approximately the same as the pressure in the steam main, open the stop valve very slightly. If there is no unusual disturbance, such as noise or vibration, continue

to open the valve slowly until it is fully open. Open the valve in the return line.

CAUTION: When the stop valve at the boiler outlet is closed, the stop valve in the return line of that boiler must also be closed.

9.5 OPERATION

9.5.1 Water Level

9.5.1.1 Whenever going on duty, immediately check the water level of all steaming boilers.

9.5.1.2 Check the water gauge regularly. The required frequency must be determined by trial. The check should be made when there is steam pressure on the boiler. Close the lower gauge glass valve, then open the drain cock that is on the bottom of this valve and blow the glass clear. Close the drain cock and open the lower gauge glass valve. Water should return to the gauge glass immediately.

(a) If water return is sluggish, leave the lower gauge glass open and close the upper gauge glass valve. Then open the drain cock and allow water to flow until it runs clear. Close the drain valve and repeat the first test described, with the lower gauge glass valve closed. If leaks appear around the water gauge glass or fittings, correct the leaks at once. Steam leaks may result in a false waterline, and they also may damage the fittings.

(b) If water disappears from the water gauge glass, blow down the gauge glass to see if water appears. If it does not appear, then stop the fuel supply immediately. Do not turn on the water feed line. Do not open the safety valve. Let the boiler cool until the crown sheet is at hand-touch temperature. Then add water to 1 in. (25 mm) in the gauge glass. Do not put the boiler back into service until the condition responsible for the low water has been identified and corrected.

(c) If the waterline is bouncing or surging, the boiler may need to be skimmed and/or cleaned.

9.5.2 Steam Pressure

A common unsafe condition found in steam heating boilers is due to the failure of the safety valve(s) to open at the set pressure. This is usually due to the buildup of corrosive deposits between the disk and seat of the safety valve, which is caused by a slight leakage or weeping of the valve.

The snap-action opening of a safety valve occurs when the boiler steam pressure on the underside of the valve disk overcomes the closing force of the valve spring. As the force of the steam pressure approaches the counteracting force of the spring, the valve tends to leak slightly and if this condition is permitted to exist, the safety valve can stick or freeze.

For this reason, the pressure differential between the safety valve set pressure and the boiler operating pressure should be at least 5 psi (35 kPa), i.e., the boiler operating pressure should not exceed 10 psig (70 kPa). If, however, the boiler operating pressure is greater than 10 psig (70 kPa), it should not exceed 15 psig (100 kPa) minus the blowdown pressure of the safety valve.

This pressure differential is also required to help ensure that the safety valve will seat tightly after popping and when the boiler pressure is reduced to normal operating pressure.

It is very important that periodic testing of safety valves is carried out in accordance with [Article 5](#).

9.5.3 Blowdown

Where low-pressure steam boilers are used solely for heating and where practically all of the condensate is returned to the boiler, blow down only as often as concentration of solids requires. Boilers used for process steam requiring high makeup should be blown down as required to maintain chemical concentrates at the desired level and to remove precipitated sediments. Boilers that are equipped with slow-opening blowoff valves and a quick-opening blowoff cock should have the levers or cocks opened first, followed by a gradual opening and closing of the slow-opening valve. When the slow-opening valve has been shut tight, then close the lever valve or cock.

CAUTION: Do not open the slow-opening valve first and pump the lever action valve open and closed as water hammer is apt to break the valve bodies or pipe fittings.

9.5.4 Appearance of Rust

The appearance of rust in the water gauge glass is an indication of corrosion that must not be ignored. Check the boiler water to be sure that the water treatment compound is at proper strength, and make sure the boiler is not requiring considerable quantities of makeup water. Check the return line and other parts of the system for evidence of corrosion.

9.5.5 Water-Level Fluctuation

A wide fluctuation of water level may indicate that the boiler is foaming or priming. This may be due to the water level in the boiler being carried too high or, especially in low-pressure boilers, a very high rate of steaming. Foaming may also be caused by dirt or oil in the boiler water. Foaming can sometimes be cured by blowing down the boiler, draining 2 in. (50 mm) or 3 in. (75 mm) of water, refilling it, then repeating the process a few times. In persistent cases, it may be necessary to take the boiler out of service, drain it and wash it out thoroughly as described in [9.1](#) and [9.2](#) for a new steam boiler installation, then refill it and put it back into service.

9.5.6 Abnormal Water Losses

In steam boilers, abnormal water losses are indicated by the need for large amounts of manually fed makeup water; in boilers with automatic water feeders, such losses are indicated by an increased need for water treatment. In either case, the problem should be investigated immediately to determine the cause. Once the cause of the water loss has been determined, parts should be repaired or replaced immediately to correct the problem; the operator should not simply increase water treatment to protect the system from excessive amounts of raw-water makeup. A water meter on the feedwater line is useful for determining the amount of makeup water entering a system. If the operator cannot determine the cause of the water loss, a competent contractor should be contacted.

9.5.7 Makeup Water

9.5.7.1 When water makeup is needed and neither the boiler nor the condensate tank is equipped with an automatic water feeder, manually add water to the steam boiler once the boiler has cooled.

9.5.7.2 Use every practical means for excluding oxygen from the boiler water. One source of oxygen is makeup water; therefore, hold makeup to a minimum. If the boiler loses more than 3 in. (75 mm) of water per month, this indicates there is probably a leak in some part of the system. The leak should be found and corrected.

9.5.7.3 If the system includes a pump for returning condensate or adding feedwater, be certain that the air vent at the receiver is operating properly.

9.5.7.4 If large quantities of feedwater are required, deaerating equipment is recommended to remove dissolved gases, thereby reducing oxygen corrosion. Consult the boiler Manufacturer and a local water treatment company for treatment recommendations and requirements.

9.5.8 Low-Water Cutoff

9.5.8.1 Check the operation of the low-water cutoff, pump control, and water feeder if one is installed. Regularly blow down each control according to the Manufacturer's instructions on the attached tag or plate.

9.5.8.2 Periodically, the low-water cutoff should be tested under actual operating conditions. With the burner operating and the boiler steaming at proper water level, close all the valves in the feedwater and condensate return lines so the boiler will not receive any replacement water. Then carefully observe the waterline to determine where the cutoff switch stops the burner in relation to the lowest permissible waterline established by the boiler Manufacturer. If the burner cutoff level is not

at, or slightly above, the lowest permissible waterline, in a new installation the low-water cutoff should be moved to the proper elevation, or in an existing installation it should be serviced, repaired, or, if necessary, replaced.

9.6 REMOVAL OF BOILER FROM SERVICE

9.6.1 General

Refer to local jurisdictional requirements and Manufacturer's instructions for the removal of a boiler from service. For boilers that will return to service at a later date, see [Article 14](#).

9.6.2 Cleaning

When the boiler is cool, clean the tubes and other fire-side heating surfaces thoroughly, and scrape the surfaces down to clean metal. Clean the smoke boxes and other areas where soot or scale may accumulate. Soot is not corrosive when it is perfectly dry but can be very corrosive when it is damp. For this reason, it is necessary to remove all the soot from a boiler at the beginning of the nonoperating season or any extended nonfiring period.

9.6.3 Protection Against Corrosion

Swab the fire-side heating surfaces with neutral mineral oil to protect against corrosion. If the boiler room is damp, place a tray of calcium chloride or unslaked lime in the combustion chamber and replace the chemical when it becomes mushy.

9.6.4 Water Level

Drain a steam boiler back to normal water level before putting the boiler back in service.

9.6.5 Periodic Checks

During the idle period, check the boiler occasionally for corrosion.

9.7 MAINTENANCE

9.7.1 Cleaning

Clean the boiler tubes and other heating surfaces whenever required. The frequency of the cleaning can best be determined by trial. A general prediction applicable to all boilers cannot be made. Also, clean the smoke boxes when required.

9.7.2 Draining

A clean, properly maintained steam-heating boiler should not be drained unless

- (a) there is a possibility of freezing
- (b) the boiler has accumulated a considerable amount of sludge or dirt on the water side, or

(c) draining is necessary to make repairs

Very little sludge should accumulate in a boiler where little makeup water is added and where an appropriate water treatment is maintained at the proper strength.

9.7.3 Protection Against Freezing

Antifreeze solutions, when used in heating systems, should be tested from year to year as recommended by the manufacturer of the antifreeze that is used. Antifreeze solutions should not be circulated through the boiler proper. The antifreeze solution should be heated in an indirect heat exchanger.

9.7.4 Fire-Side Corrosion

Boilers corrode on the fire side. Some fuels contain substances that cause fire-side corrosion. Sulfur, vanadium, and sodium are among the materials that may contribute to this problem.

(a) Deposits of sulfur compounds may cause fire-side corrosion. The probability of trouble from this source depends on the amount of sulfur in the fuel and on the care used in cleaning the fire-side heating surfaces. This is particularly true when preparing a boiler for a period of idleness. Preventing this trouble depends also on keeping the boiler heating surfaces dry when a boiler is out of service.

(b) Deposits of vanadium or vanadium and sodium compounds also may cause fire-side corrosion, and these compounds may be corrosive during the season when boilers are in service.

The person responsible for boiler maintenance should be certain that the fire-side surfaces of the boilers are thoroughly cleaned at the end of the firing season. If signs of abnormal corrosion are discovered, a reputable consultant should be engaged.

9.7.5 Safety Valves

Safety valves on steam boilers should be tested for proper operation in accordance with 6.7. ASME-rated safety valves shall be installed on the boiler where required by jurisdictional regulations. When replacement is necessary, use only ASME-rated valves of the required capacity.

9.7.6 Burner Maintenance

9.7.6.1 Oil Burners. Oil burners require periodic maintenance to keep the nozzle and other parts clean. Check and clean oil-line strainers. Examine and check the nozzle, and check the oil level in the gear cases. Check and clean filters, air intake screens, blowers, and air passages. Check all linkages and belts, and adjust as required. Lubricate in accordance with Manufacturer's instructions. Check pilot burners and ignition equipment for proper flame adjustment and performance with a combustion analyzer.

9.7.6.2 Gas Burners. Check gas burners for presence of dirt, lint, or foreign matter. Make sure that parts, gas passages, and air passages are free of obstructions. Linkages, belts, and moving parts on power burners should be checked for proper adjustment. Check gas outlets on combination oil and gas burners; after prolonged periods of oil firing, these outlets may become caked with carbon residues from unburned fuel oil and require cleaning. Lubricate in accordance with the Manufacturer's instructions. Also check pilot burners and ignition equipment for proper flame adjustment and performance.

9.7.7 Low-Water Fuel Cutoff and Water Feeder Maintenance

Low-water fuel cutoffs and water feeders should be dismantled annually, by qualified personnel, to the extent necessary to ensure freedom from obstructions and proper functioning of the working parts. Examine connecting lines to boiler for accumulation of mud, scale, etc., and clean as required. Examine all visible wiring for brittle or worn insulation, and make sure electrical contacts are clean and that they function properly. Give special attention to solder joints on bellows and float when this type of control is used. Check float for evidence of collapse, and check mercury bulb (where applicable) for mercury separation or discoloration. Do not attempt to repair mechanisms in the field. Complete replacement mechanisms, including necessary gaskets and installation instructions, are available from the Manufacturer. After reassembly, test as per 9.5.8.2.

9.7.8 Flame Safeguard Maintenance

9.7.8.1 Thermal-Type Detection Device. Check the device for electrical continuity and satisfactory current generation in accordance with the Manufacturer's instructions.

9.7.8.2 Electronic-Type Detection Device. Check operation of the unit in accordance with the Manufacturer's instructions, and examine for damaged or worn parts. Do not attempt to repair these units in the field.

9.7.9 Limit Control Maintenance

Maintenance on pressure-limiting controls is generally limited to visual examination of the device for evidence of wear, corrosion, etc. If the control is of the mercury bulb type, check for mercury separation and discoloration of the bulb. If the control is defective, replace it. Do not attempt to make field repairs.

9.7.10 Cast Iron Boiler Maintenance

9.7.10.1 Heating Surfaces. Check the firebox gas passages and breeching for soot accumulation. Use a wire brush and vacuum cleaner, if required, to remove the soot or other dirt accumulations.

9.7.10.2 Internal Surfaces. If the condition of the water in the boiler indicates that there is considerable foreign matter in it, the boiler should be allowed to cool, then it should be drained and thoroughly flushed out. Remove the blowdown valves and plugs in the front and rear sections, and wash through these openings with a high-pressure water stream. This will normally remove any sludge or loose scale. If there is evidence that hard scale has formed on the internal surfaces, the boiler should be cleaned by chemical means as prescribed by a qualified water treatment specialist.

9.7.11 Steel and Copper Boiler Maintenance

9.7.11.1 Heating Surfaces. Remove all accumulations of soot, carbon, and dirt from the fire side of the boiler. Use a flue brush to clean the tubes. Clean breeching and stack as required. Examine refractory and make repairs as required.

9.7.11.2 Boilers With Removable Waterway Covers. Blow down as specified in 9.5.3. If water does not run clear, the boiler should be cleaned. After the boiler is allowed to cool, the cleaning is accomplished by venting and draining the boiler, removing all manhole and handhole covers, and washing the inside of the boiler with a high-pressure water stream. Loosen any solidified sludge, scale, etc., with a hand scraper. Start at the top of the boiler and work down. Flush thoroughly after cleaning. Where access is limited or where scale buildup is difficult to remove, it may be necessary to clean the boiler chemically as prescribed by a qualified water treatment specialist.

9.7.11.3 Boilers Without Removable Waterway Covers. After the boiler is allowed to cool, close the isolation valves on the piping to isolate the boiler from the system. Attach a hose to the boiler drain and flush the boiler thoroughly with clean water by using purging valves to allow water to flow through the water makeup line to the boiler.

9.7.12 Use of Flashlight for Internal Examination

When practical, use a flashlight rather than an extension light for internal examination purposes. Follow proper safety procedures if entering the boiler.

9.7.13 Leaking Tubes

If one tube in a boiler develops a leak due to corrosion, it is likely that other tubes are also corroded. Have the boiler examined by a capable and experienced person before ordering the replacement of one or a few tubes. If all the tubes will need replacement soon, it is preferable and less expensive to have all the work done at the same time.

9.7.14 Use of Sealant

The use of sealant is not recommended in a steam boiler.

9.7.15 Maintenance of Condensate Return Systems

Examine and clean the strainer ahead of the pump. Drain and flush the condensate tank. Check pump packing, float switches, and vacuum switches, as applicable. For detailed instructions, refer to the Manufacturer's maintenance data and instructions.

9.7.16 Maintenance Schedule for Boilers in Service

Refer to the boiler Manufacturer's instructions for maintenance requirements and schedules.

ARTICLE 10

OPERATION AND MAINTENANCE — HOT WATER BOILERS AND HOT WATER HEATING BOILERS

10.1 STARTING A NEW BOILER AND HEATING SYSTEM

A new boiler should be cleaned and filled as detailed in 10.1.1 through 10.1.3.

10.1.1 Examination for Foreign Objects

Prior to starting a new boiler, the boiler should be examined to ensure that no foreign matter, such as tools, equipment, or rags, has been left in the boiler.

10.1.2 Checks Before Filling

Before putting water into a new boiler, make certain that the firing equipment is in operating condition to the extent that this is possible without actually lighting a fire in the empty boiler. This is necessary because raw water must be boiled [or heated to at least 180°F (82°C)] promptly after it is introduced into the boiler in order to drive off the dissolved gases that might otherwise corrode the boiler. In a hot water heating system, the boiler and entire system (other than the expansion tank) must be full of water for satisfactory operation. The red, or fixed, hand on the combination altitude gauge and thermometer is normally set to indicate the amount of pressure required to fill the system with cold water. Water should be added to the system until the black hand registers the same or more than the red hand. To ensure that the system is full, water should come out of all air vents when the vents are opened.

10.1.3 Boiling Out

A qualified chemical water treatment specialist should be consulted for recommendations regarding appropriate chemical compounds and concentrations that are compatible with local environmental regulations governing disposal of the boil-out solutions. The oil and grease that accumulate in a new hot water boiler can be washed out in the following manner:

- Step 1.* Add an appropriate boil-out compound.
- Step 2.* Fill the entire system with water.
- Step 3.* Start the firing equipment.
- Step 4.* Circulate the water through the entire system.
- Step 5.* Vent the system, including the radiation.

Step 6. Allow boiler water to reach operating temperature, if possible.

Step 7. Continue to circulate the water for a few hours.

Step 8. Stop the firing equipment.

Step 9. Drain the system in a manner and to a location that allow the hot water to be discharged safely.

Step 10. Wash the water side of the boiler thoroughly using a high-pressure water stream.

Step 11. Refill the system with fresh water.

Step 12. Promptly heat the water to at least 180°F (82°C), and vent the system at the highest point.

Step 13. Tighten handhole covers, manhole covers, and plugs while the boiler is hot.

The boiler is now ready to be put into service or on standby.

10.2 STARTING A BOILER AFTER LAYUP (SINGLE-BOILER INSTALLATION)

10.2.1 Procedure

When starting a boiler after layup, proceed as follows:

Step 1. Review Manufacturer's instructions for startup of the burner and boiler.

Step 2. Fill the boiler and system; vent air at the high point in the system.

Step 3. Check the altitude gauge and expansion tank to ensure the system is properly filled.

Step 4. Set the control switch to the "Off" position.

Step 5. Make sure fresh air to the boiler room is unobstructed and manual dampers are open.

Step 6. Check availability of fuel.

Step 7. Vent the combustion chamber to remove unburned gases.

Step 8. Clean the glass on the fire scanner, if provided.

Step 9. Observe proper functioning of the water pressure regulator and turn circulator pumps on electrically.

Step 10. Check temperature control(s) for proper setting.

Step 11. Check the manual reset button on the low-water fuel cutoff and high-limit temperature control.

Step 12. Set the manual fuel oil supply or manual gas valve to the open position.

Step 13. Place the circuit breaker or fuse disconnect in the "On" position.

Step 14. Place all boiler emergency switches in the “On” position.

Step 15. Place the boiler control starting switch in the “On” or “Start” position. (Do not stand in front of boiler doors or breeching.)

Step 16. Do not leave the boiler until it reaches the established cutout point, to make sure the controls shut off the burner.

Step 17. During the temperature and pressure buildup period, walk around the boiler frequently to observe that all associated equipment and piping are functioning properly. Visually check the burner for proper combustion.

Step 18. Immediately after the burner shuts off, check the water pressure and open the highest vent to determine that the system is completely full of water.

Step 19. In the logbook, enter the following:

(a) date and time of startup, any irregularities observed, and corrective action taken

(b) time when controls shut off the burner at established temperature, tests performed, etc.

(c) signature of operator

Step 20. Check the safety relief valve for evidence of leaking. Perform try-lever test as described in 6.8.

10.2.2 Action in Case of Abnormal Conditions

If any abnormal conditions occur during light-off or temperature buildup, immediately shutdown the boiler. (Do not attempt to restart the unit until difficulties have been identified and corrected.)

10.3 CONDENSATION

Following a cold start, condensation may occur in a gas-fired boiler to such an extent that it appears that the boiler is leaking. This condensation can be expected to stop after the boiler is hot. This is different from the flue-gas condensate, which is present for heating boilers operated in condensing mode. Refer to the Manufacturer’s instructions for proper handling of the condensate.

10.4 CUTTING IN AN ADDITIONAL BOILER

When placing a boiler on the line with other boilers that are already in service, care must be taken to ensure that the Manufacturer’s required minimum flow rates are met and that the water outlet temperature is raised slowly enough to avoid thermal shock. Consult the Manufacturer’s owner’s manual for the proper procedure.

10.5 OPERATION

10.5.1 Check of Pressure and Temperature

Whenever going on duty, check the pressure and temperature in all water boilers.

10.5.2 Operating Temperature and Pressure

10.5.2.1 Operating Temperature. The maximum operating temperature of the boiler water should never exceed 250°F (120°C), and should be no higher than is necessary to adequately heat the space under design conditions. Higher temperatures will accelerate any corrosion process.

10.5.2.2 Operating Pressure. A common unsafe condition found in hot water heating boilers is due to the failure of the safety relief valve(s) to open at the set pressure. This is usually due to buildup of corrosive deposits between the disk and seat of the valve, which is caused by a slight leakage or weeping of the valve.

The opening of a safety relief valve occurs when the boiler water pressure on the underside of the valve disk overcomes the closing force of the valve spring. As the force of the water pressure approaches the counteracting force of the spring, the valve tends to leak slightly and if this condition is permitted to exist, the safety relief valve can stick or freeze.

For this reason, the pressure differential between the safety relief valve set pressure and the boiler operating pressure should be at least 10 psi (69 kPa) or 25% of the valve set pressure, whichever is greater.

10.5.2.3 Temperature and Pressure Safety Relief Valves. When equipped with a temperature and pressure safety relief valve, the boiler is limited to a maximum temperature of 210°F (99°C) have a temperature and pressure safety relief valve installed, the operating temperature must be low enough to prevent routine operation of the thermal element, which could lead to degradation of the valve.

When the thermal element opens, it will not close until the temperature has been reduced by 25°F to 35°F (–3.9°C to 1.7°C) below the opening temperature. Therefore, the maximum operating temperature should not exceed 160°F (71°C).

10.6 REMOVAL OF BOILER FROM SERVICE

10.6.1 General

Refer to local jurisdictional requirements and Manufacturer’s instructions for the removal of a boiler from service. For boilers that will return to service at a later date, see [Article 14](#).

10.6.2 Cleaning

When the boiler is cool, clean the tubes and other heating surfaces thoroughly, and scrape the surfaces down to clean metal. Clean the smoke boxes and other areas where soot or scale may accumulate. Soot is not corrosive when it is perfectly dry but can be very corrosive when it is damp. For this reason, it is necessary to remove

all the soot from a boiler at the beginning of the nonoperating season or any extended nonfiring period.

10.6.3 Protection Against Corrosion

Swab the fire-side heating surfaces with neutral mineral oil to protect against corrosion. If the boiler room is damp, place a tray of calcium chloride or unslaked lime in the combustion chamber and replace the chemical when it becomes mushy.

10.6.4 Periodic Checks

During the idle period, check the boiler periodically for corrosion.

10.7 MAINTENANCE

10.7.1 Cleaning

10.7.1.1 General. Clean the boiler tubes and other heating surfaces whenever required. The frequency of the cleaning can best be determined by trial. A general prediction applicable to all boilers cannot be made. Also, clean the smoke boxes when required.

10.7.1.2 Backwashing of Water Heater. Any water heater installed in or connected to a boiler should be backwashed periodically, using valves to reverse the direction of flow through the heater. The purpose of this backwashing is to reduce the amount of scale that will accumulate at the outlet side of the heater. Continue the backwashing until the water runs clear. The backwashing should be done frequently, and the maximum interval should be determined by site conditions.

10.7.2 Draining

A clean, properly maintained heating boiler should not be drained unless

- (a) there is a possibility of freezing
- (b) the boiler has accumulated a considerable amount of sludge or dirt on the water side, or
- (c) draining is necessary to make repairs

Very little sludge should accumulate in a boiler where little makeup water is added and where an appropriate water treatment is maintained at the proper strength. If it proves necessary to drain the boiler and heating piping to do repair work, and the various parts of the system cannot be isolated to prevent such draining, it would be wise to consider the installation of valves and drains at that time to prevent this from occurring again. Use of such valves and drains will save considerable time and expense the next time repairs are necessary, and the amount of raw water required will also be reduced.

10.7.3 Protection Against Freezing

Antifreeze solutions when used in heating systems shall be those recommended by the boiler Manufacturer.

10.7.3.1 The service life of an antifreeze solution depends on such factors as heating system design and condition, hours of operation, solution and metal temperatures, aeration, and rate of contamination. Therefore, the antifreeze solution should be tested at least once a year and as recommended by the manufacturer of the antifreeze that is used. High metal temperatures accelerate depletion of the antifreeze inhibitors. For maximum service life of the antifreeze solution, the metal temperature in contact with the solution should be kept under 350°F (176°C).

10.7.3.2 Antifreeze solution is harmful or may be fatal if swallowed; therefore, antifreeze solutions should be used only in closed circulating systems entirely separated from potable water supply systems.

10.7.3.3 Antifreeze solutions expand more than water for a given rise in temperature. Allowance must be made for this expansion when an antifreeze solution is used in a heating system.

10.7.4 Fire-Side Corrosion

Boilers can corrode on the fire side. Some fuels contain substances that cause fire-side corrosion. Sulfur, vanadium, and sodium are among the materials that may contribute to this problem.

(a) Deposits of sulfur compounds may cause fire-side corrosion. The probability of trouble from this source depends on the amount of sulfur in the fuel and on the care used in cleaning the fire-side heating surfaces. This is particularly true when preparing a boiler for a period of idleness. Preventing this trouble depends also on keeping the boiler heating surfaces dry when a boiler is out of service.

(b) Deposits of vanadium or vanadium and sodium compound also may cause fire-side corrosion, and these compounds may be corrosive during the season when boilers are in service.

The person responsible for boiler maintenance should be certain that the fire-side surfaces of the boilers are thoroughly cleaned at the end of the firing season. If signs of abnormal corrosion are discovered, a reputable consultant should be engaged.

10.7.5 Safety Relief Valves

Safety relief valves on hot water heating and hot water supply boilers should be tested for proper operation in accordance with 6.8. ASME-rated valves shall be installed on a boiler where required by jurisdictional regulations. When replacement is necessary, use only ASME-rated valves of the required capacity.

10.7.6 Burner Maintenance

10.7.6.1 Oil Burners. Oil burners require periodic maintenance to keep the nozzle and other parts clean. Check and clean oil-line strainers. Examine and check the nozzle, and check the oil level in the gear cases, if applicable. Check and clean filters, air intake screens, blowers, and air passages. Check all linkages and belts, and adjust as required. Lubricate in accordance with the Manufacturer's instructions. Check pilot burners and ignition equipment for proper flame adjustment and performance.

10.7.6.2 Gas Burners. Check gas burners for presence of dirt, lint, or foreign matter. Make sure that ports, gas passages, and air passages are free of obstructions. Check linkages, belts, and moving parts on power burners for proper adjustment. Check gas outlets on combination oil and gas burners; after prolonged periods of oil firing, these outlets may become caked with carbon residue from unburned fuel oil and require cleaning. Lubricate in accordance with Manufacturer's instructions. Also check pilot burners and ignition equipment for proper flame adjustment and performance.

10.7.7 Low-Water Fuel Cutoff

Low-water fuel cutoffs and water feeders should be dismantled annually by qualified personnel, to the extent necessary to ensure freedom from obstructions and proper functioning of the working parts. Examine connecting lines to the boiler for accumulation of mud, scale, etc., and clean as required. Examine all visible wiring for brittle or worn insulation, and make sure electrical contacts are clean and that they function properly. Give special attention to solder joints on bellows and float when this type of control is used. Check float for evidence of collapse, and check mercury bulb (where applicable) for mercury separation or discoloration. Do not attempt to repair mechanisms in the field. Complete replacement mechanisms, including necessary gaskets and installation instructions, are available from the Manufacturer. After reassembly, test, if installation permits, without draining water from the boiler.

10.7.8 Flame Safeguard Maintenance

10.7.8.1 Thermal-Type Detection Device. Check the device for electrical continuity and satisfactory current generation in accordance with the Manufacturer's instructions.

10.7.8.2 Electronic-Type Detection Device. Check operation of the unit in accordance with the Manufacturer's instructions, and examine for damaged or worn parts. Do not attempt to repair these units in the field.

10.7.9 Limit Control Maintenance

Maintenance on temperature-limiting control is generally limited to visual examination of the device for evidence of wear, corrosion, etc. If the control is of the mercury bulb type, check for mercury separation and discoloration of the bulb. If the control is defective, replace it. Do not attempt to make field repairs.

10.7.10 Cast Boiler Maintenance

10.7.10.1 Heating Surfaces. Check the firebox gas passages and breeching for soot accumulation. Use a wire brush and vacuum cleaner, if required, to remove the soot or other dirt accumulation per the Manufacturer's instructions.

10.7.10.2 Internal Surfaces. If the condition of the water in the boiler indicates that there is considerable foreign matter in it, the boiler should be allowed to cool, then it should be drained and thoroughly flushed out. Remove the washout plugs and wash through the openings with a high-pressure water stream. This will normally remove any sludge or loose scale. If there is evidence that hard scale has formed on the internal surfaces, the boiler should be cleaned by chemical means as prescribed by a qualified water treatment specialist.

10.7.11 Steel Boiler Maintenance

10.7.11.1 Heating Surfaces. Remove all accumulations of soot, carbon, and dirt from the fire side of the boiler. Use a flue brush to clean the tubes. Clean breeching and stack as required. Examine refractory and make repairs as required.

10.7.11.2 Internal Surfaces. If the condition of the water in the boiler indicates that there is considerable foreign matter in it, the boiler should be allowed to cool, then it should be drained and thoroughly flushed out. Remove all handhole and manhole covers and wash through these openings with a high-pressure water stream. This will normally remove any sludge or loose scale. If there is evidence that hard scale has formed on the internal surfaces, the boiler should be cleaned by chemical means as prescribed by a qualified water treatment specialist.

10.7.12 Use of Flashlight for Internal Examinations

When practical, use a flashlight rather than an extension light for internal inspection purposes. Follow proper safety procedures if entering the boiler.

10.7.13 Leaking Tubes

If one tube in a boiler develops a leak due to corrosion, it is likely that other tubes are also corroded. Have the boiler examined by a capable and experienced person before ordering the replacement of one or a few tubes. If all the tubes will need replacement soon, it is preferable and less expensive to have all the work done at the same time.

10.7.14 Use of Sealants

Sealants may have a detrimental effect on boilers, pumps, safety relief valves, etc.; therefore, their use is not recommended in hot water heating or hot water supply boilers.

10.7.15 Maintenance of Circulating Pumps and Expansion Tanks

Inspect the circulating pump(s) and lubricate in accordance with the Manufacturer's instructions. Check the operation of all associated controls, switches, etc. Examine the expansion tank for dirt, tightness, and evidence of corrosion. Clean and repair as required. For detailed instructions, refer to the Manufacturer's literature, instructions, and data.

10.7.16 Maintenance Schedule for Boilers in Service

Refer to the boiler Manufacturer's instructions for maintenance requirements and schedules.

ARTICLE 11

INSPECTIONS OF INSTALLED BOILERS

11.1 PERIODIC INSPECTION OF BOILERS

Periodic inspection is necessary to protect against loss or damage to the pressure vessel because of corrosion, pitting, etc., and to protect against unsafe operating conditions. The following pre-inspection procedures are recommended to ensure a thorough and complete inspection:

(a) All boilers should be prepared for inspection, whenever necessary, by the owner or user when notified by the inspector. The owner or user should prepare the boiler for an internal inspection and should prepare for and apply the liquid pressure test, whenever necessary, on the date specified in the presence of a qualified inspector.

(b) Before inspection, every part of a boiler that is accessible should be open and properly prepared for internal and external examination. In cooling down a boiler for inspection or repairs, the owner or user should not withdraw the water until the boiler is sufficiently cooled, to avoid damage. The cool-down process should be in accordance with the Manufacturer's recommendations.

11.1.1 Preparation for Inspection

The owner or user should prepare a boiler for internal inspection in the following manner:

- (a) Drain water.
- (b) Remove all manhole and handhole plates, plugs (washout and piping), and water column connections.
- (c) Remove all grates of internally fired boilers.
- (d) Remove brickwork as required by the inspector to determine the condition of the furnace, supports, or other parts.
- (e) Cut off any leakage of steam or hot water into the boiler by disconnecting the pipe or valve at the most convenient point.
- (f) Thoroughly clean the boiler on both water sides and fire sides. Take special care to ensure fire-side soot buildup and water-side mineral deposits are removed.

Where there is moisture, discoloration, or vapor showing through the covering, the covering should be removed by a qualified individual (in accordance with local regulations and Manufacturer's instructions) and a complete investigation made. Every effort should be made to discover the true condition of a boiler.

11.1.2 Preparation for the Liquid Pressure Test

Obtain guidance from the inspector regarding the preparation for this test.

11.2 INSPECTION OF THE BOILER BY THE INSPECTOR

The boiler inspector should inspect the boiler in accordance with local jurisdictional requirements. If there are none, the inspector should inspect the boiler in accordance with NB-23, National Board Inspection Code.

The inspector, whether an employee of a state, province, municipality, or insurance company, should be well informed of the natural and neglectful causes of defects and deterioration of boilers. The inspector should be extremely conscientious and careful during the inspection, taking sufficient time to perform thorough examinations, taking no one's statement as final as to conditions he has not directly observed, and, if unable to make a thorough inspection, noting so in the inspection report. The inspector should assess the overall condition of the boiler room and apparatus, and observe the attendants and any maintenance, testing, and inspection logs (see [Mandatory Appendix I, Figures I-1-1 and I-1-2](#)) as a guide in forming an opinion of the general care of the equipment. The inspector should question responsible employees as to the history of old boilers and their peculiarities and behavior, and ascertain what, if any, repairs have been made and their character, and whether they were made properly and safely.

ARTICLE 12 BOILER REPAIRS

12.1 PRECAUTION

Do not permit repairs to a boiler while it is in service or under pressure, except with the approval and under the supervision of an authorized boiler inspector or responsible engineer.

12.2 NOTIFICATION

When repair work is required, notify the authorized boiler and pressure vessel inspector and be guided by the inspector's recommendations.

12.3 WELDING REQUIREMENTS

All repair work should be done by experienced boiler mechanics. All welding should be done by qualified welders using procedures properly qualified according to Section IX.

12.4 SAFETY

Take every precaution necessary to ensure against injury to those working in the boiler room and particularly to those working inside the steam space or in the combustion chamber of the boiler. Pull the main burner switch and lock it out and tag it, swing the burner out of place if possible, close and lock valves, etc., and always have one person standing by outside when anyone is working inside a boiler.

ARTICLE 13

WATER TREATMENT

13.1 SCOPE

This Article covers recommended procedures for the treatment of water in steam and hot water heating boilers.

13.2 CONSIDERATIONS

Operational experience and corrosion research have clearly shown that the problem of accelerated scaling may be eliminated through properly administered boiler water treatment. Employing a conscientious and competently administered program with emphasis on good maintenance practices as outlined by a water treatment specialist is recommended.

Consider the following factors when deciding whether to treat the water and, if so, what type of treatment to use:

- (a) type of boiler, i.e., cast iron or steel, steam or hot water
- (b) nature of the raw water, i.e., hard or soft, corrosive or scale forming
- (c) amount of makeup water required and any blow-down requirements
- (d) preliminary treatment of the water, i.e., softeners, preheaters, deaerators
- (e) use of the steam, i.e., for heating only or a combination of other purposes
- (f) amount of supervision and control testing available

13.3 WATER TREATMENT SPECIALISTS

Each boiler installation should be considered on an individual basis. If there appears to be any question regarding the treatment required, review the boiler Manufacturer's instructions and the final treatment decision with a reputable water treatment company. These companies furnish a service and/or chemicals for boiler water treatment. They are in a position to make recommendations based on local water conditions and the particular installation involved. They also furnish test kits accompanied by simple analytical procedures for day-to-day analysis by the local maintenance personnel. Samples are taken at suitable intervals and sent to their laboratories for confirmation analysis. In setting up arrangements with such concerns, do not hesitate to ask for the chemical composition of, and other technical information involved in, the treatments prescribed.

13.4 LOCAL ORDINANCES

Make sure that all the water treatment chemicals used and their disposal process do not violate any local ordinances.

13.5 POTENTIAL BOILER WATER PROBLEMS

13.5.1 Corrosion

Raw water as received from city mains or wells may contain impurities, including dissolved gases such as oxygen and carbon dioxide. When the water is soft, it is acidic and corrosive; such water can negatively affect boiler metals and condensate return lines, resulting in general overall corrosion or localized pitting or cracking in stressed metal. High temperatures can accelerate these reactions. If uncorrected, serious pitting can result in the possible rupture of boiler tubes. Rusty water in the gauge glass is a sure sign of corrosion in the heating system or in the boiler itself.

13.5.2 Scale Deposits

All water contains dissolved salts. Where water is hard, these are mainly calcium and magnesium compounds. Under boiler operating conditions, these salts come out of solution and form scale deposits on the boiler metal. This is due to decomposition of the bicarbonates and to the decreased solubility of calcium salts at higher temperatures. As the water is evaporated, the solids are left behind and scale deposits build up. The scale forms an insulating barrier on the boiler tubes, resulting in poorer heat transfer and lower efficiency. Scale deposits can also cause overheating and failure of boiler tubes.

13.5.3 Metal or Caustic Embrittlement

Under certain conditions of high caustic alkalinity where the metal is under stress, cracks can develop in the metal below the waterline and under rivets, welds, and longitudinal seams. This type of failure is typically found in steel boilers.

13.5.4 Foaming, Priming, and Carryover

Foaming, priming, and carryover, which occur in steam boilers only, are closely associated with and refer to the formation of froth and suds on the surface of the water.

Where this is severe, boiler water is carried over with the steam. Excessive dissolved solids carried over can form deposits in the steam piping and valves, which can cause a loss of efficiency and adversely affect the operation of the boiler and system components.

13.6 BLOWDOWN (STEAM BOILERS)

The purpose of blowdown on steam boilers is to keep the amount of dissolved solids and sludge in the boiler water under control. As the water is turned into steam, the solids remain behind, and, unless there is 100% condensate return, the solids content tends to build up. As a rule of thumb, about 1,000 ppm can be considered a safe maximum. A hard water containing 200 ppm in the feedwater would tolerate five concentrations in the boiler. On the other hand, a soft water with 25 ppm solids could concentrate 400 times before reaching the critical point. To maintain satisfactory operational conditions, the hard water would require 20% blowdown while the soft would require only 2%. With soft water, blowdown can possibly be held to once or twice a season. With hard water, blowdown may be necessary once a month or even once a week. Blowdown should be held to a minimum, since it involves heat losses and, if excessive, wastes treatment chemicals. Drains receiving blowdown water should be connected to the sanitary sewer.

13.7 CHEMICAL FEEDERS

Simple chemical feeders are preferable, particularly where the treatment is to be added periodically, i.e., more than once or twice a season. Where there is any appreciable amount of blowdown, or loss of condensate, additional treatment will be necessary from time to time. A number of different feeder types may be used. These include open-type gravity feeders where the treatment is to be fed manually in one slug or in periodic small shots; closed-type gravity-drip and bypass feeders where the treatment is to be fed in proportion to the amount of makeup water; and pot-type proportional feeders where slowly dissolving treatment crystals or briquettes are used.

13.8 PROCEDURES

13.8.1 Determination of Water-Containing Capacity

It is necessary to know the water-containing capacity of the boiler so instructions can be given regarding the required amount of boiler water treatment compound. If this information is not given on the boiler, in the boiler catalog, or other publications, then meter the water at the time of the initial filling and record the information.

13.8.2 Making a pH or Alkalinity Test

The condition of the boiler water can be quickly tested with hydrion paper, which is used in the same manner as litmus paper, except it gives specific readings. A color chart on the side of the small hydrion dispenser gives the reading in pH. Hydrion paper is inexpensive and obtainable from any chemical supply house or through a local druggist. If a more precise measurement of pH is desired, a color slide comparator kit or pH meter is recommended.

13.8.3 Mixing and Handling Chemicals

The chemicals, if liquid, should be diluted or, if solid, dissolved in accordance with the supplier's directions before they are added to the system. If the treatment is a solid, make sure it is fully dissolved. A simple hand paddle to stir the solution is frequently all that is necessary. If the chemicals are slow to dissolve, a steam line for heating the water and agitating the mixture may be used to accelerate the process. The use of compressed air for this purpose is undesirable since it will introduce additional oxygen that will neutralize reducing agents such as sodium sulfite. Since the treatment chemicals may be highly alkaline or skin irritating, it is advisable that personnel wear goggles and gloves when they are handling or mixing them. It is extremely important that personnel be aware of the potential hazards whenever handling water treatment chemicals and that they closely follow all safety precautions recommended by the chemical manufacturer. The Material Safety Data Sheets (MSDS) should be readily available for anyone handling or involved in the use of water treatment chemicals.

ARTICLE 14

TREATMENT OF LAID-UP BOILERS

14.1 GENERAL

When steel boilers are out of service for any length of time, such as a layup for the summer, they must be protected from corrosion. This may be done either by draining them and keeping the surfaces thoroughly dry or by completely filling the boiler with properly treated water.

14.2 DRY METHOD

The boiler is drained, flushed, and inspected. The surfaces are then thoroughly dried by means of hot air. If the boiler room is dry and well ventilated, the boiler may be left open to the atmosphere. An alternate procedure is to use a suitable moisture absorbent, such as quicklime or silica gel, which is placed in the boiler in a suitable location. The boiler is then tightly closed. Every 2 or 3 months, the boiler should be checked and the lime or gel replaced or regenerated, if necessary. The dry method is not used on cast iron boilers.

14.3 WET METHOD

The boiler is drained, flushed, and inspected. It is then filled to the normal water level and steamed for a short time with the boiler vented to the atmosphere to expel dissolved gases. If the boiler is to be used to heat water or for reheat in connection with an air-conditioning system, it may be left in this state, ready to operate. If, however, it is to be completely idle for some time, it is preferable to fill the boiler to the top of the drum. In any case, treatment should be used. This may be the regularly used treatment, or a caustic soda (400 ppm) and sodium sulfite mixture (100 ppm), or sodium chromate, in which case a minimum of at least 100 ppm should be maintained on steam boilers and 300 ppm on hot water boilers. During the downtime, if feasible, it is good practice to occasionally circulate the water with a pump. This is necessary to prevent stratification and to ensure that fresh inhibitor is in contact with the metal. This is also true of hot water systems. Corrosion is apt to be more serious during the downtime than when the boiler is actually in service. The wet method is generally used on cast iron boilers.

MANDATORY APPENDIX I

PERIODIC TESTING AND MAINTENANCE

I-1 INSPECTION AND MAINTENANCE PROGRAM

Since the effective operation of all safety devices depends on their ability to respond to their activating impulses, a thorough inspection and maintenance program should be established and performed on a periodic basis. The program should comply with the following:

(a) The inspection and maintenance program should be at least that recommended by the manufacturer.

(b) Operability and set points, where applicable, on all devices shall be verified by periodic testing, and the results shall be recorded in the boiler log, maintenance record, service invoice, or other written record (see [Figures I-1-1](#) and [I-1-2](#) for examples). The manufacturer's instructions should be followed.

(c) Any defects found during testing and/or inspection should be brought to the attention of the boiler's owner and corrected immediately.

(d) Frequent inspection, adjustment, and cleaning should be performed during initial startup operation to ensure all safety controls and devices are functioning as intended and are in a reliable operating condition.

I-2 RESPONSIBILITIES OF PERSONNEL

(a) The qualified individual performing inspections and tests should be trained and familiar with all operating procedures and equipment functions and should be capable of determining that the equipment is in an as-designed operating condition. The individual should be familiar with all precautions and should comply with the requirements of the authority having jurisdiction.

(b) Because of the variety of equipment and modes of operation, owners and users should provide a detailed checklist for the operator's use in accordance with Manufacturer's instructions for the boiler, boiler unit, burner, and control device assembly.

Figure I-1-1 Exhibit A

EXHIBIT A

Maintenance, Testing, and Inspection Log Steam Heating Boilers	Building:		Month:	Year:																											
	Address:		Fuel Type:																												
Person(s) to be Notified in Emergency (Name and Telephone No.):			Boiler No.:																												
DAILY CHECKS																															
	1	2	3	4	5	6	7	8	9	10	11	12	13	14	15	16	17	18	19	20	21	22	23	24	25	26	27	28	29	30	31
(1) Observe Water Level																															
(2) Record Pressure																															
(3) Record Flue Gas Temperature																															
WEEKLY CHECKS (Enter Date)																															
	WEEK 1		WEEK 2		WEEK 3		WEEK 4																								
(1) Test Low Water Cutoff																															
(2) Test Gage Glass																															
(3) Observe Flame Condition																															
MONTHLY CHECKS (Enter Date)																															
(1) Manual Lift Safety Valve																															
(2) Review Condition of or Test Each Item	(A) Linkages			(F) Floor Drains																											
	(B) Damper Controls			(G) Flame Detection Device																											
	(C) Stop Valves			(H) Limit Controls																											
	(D) Refractory			(I) Operating Controls																											
	(E) Flue-Chimney Breeching																														
(3) Inspect Fuel Piping																															
(4) Combustion Air Adequate/Unobstructed																															
General Comments:																															

(Instructions on Reverse)

Figure I-1-1 Exhibit A (Cont'd)

EXHIBIT A (Back)

INSTRUCTIONS

- I. Fill in the name of the building, its location, boiler number, fuel type used, and the year. Name the person to be contacted in an emergency or malfunction.

- II. Daily Checks
 - (1) Observe water level in the water column sight glass (see ASME Section VI — 9.5.1).
 - (2) Record boiler pressure indicated by the gage at the boiler.
 - (3) Record the flue-gas temperature. (This should be read with the boiler running and at pressure.)

- III. Weekly Checks (Record the date the test or check was completed.)
 - (1) Drain float chamber while boiler is running to determine if the control will shut down the boiler (see ASME Section VI — 9.5.8).
 - (2) Close the lower gage gas valve, then open drain cock that is on the bottom of this valve and blow the glass clear. Close the drain cock and open lower gage glass valve. Water should return to the gage glass immediately (see ASME Section VI — 9.5.1).
 - (3) Observe flame condition.

- IV. Monthly Checks (Record the date the test or check was completed.)
 - (1) Lift try lever to full open and release it to snap shut (see ASME Section VI — 6.7).
 - (2) Review the condition of or test each item per Manufacturer's instructions.
 - (A) Check linkages for damage or disconnection (see ASME Section VI — 9.7.6).
 - (B) Watch damper controls during operation to be sure they operate properly.
 - (C) Check stop valves.
 - (D) If possible without opening boiler, check the refractory for cracking and deterioration.
 - (E) Check the flue-chimney breeching for signs of leakage, damage, or deterioration.
 - (F) Test floor drains to be sure they are draining properly.
 - (G) Test flame detection device.
 - (H) Test limit controls.
 - (I) Test operating controls.
 - (3) Inspect fuel piping for leakage and damage.

- V. Log Retention

Retain this log for at least 1 year (see ASME Section VI — 5.13).

Figure I-1-2 Exhibit B

EXHIBIT B

Maintenance, Testing, and Inspection Log Hot Water Heating Boilers		Building:		Month:	Year:																										
		Address:		Fuel Type:																											
Person(s) to be Notified in Emergency (Name and Telephone No.):					Boiler No.:																										
DAILY CHECKS																															
	1	2	3	4	5	6	7	8	9	10	11	12	13	14	15	16	17	18	19	20	21	22	23	24	25	26	27	28	29	30	31
(1) Record Pressure																															
(2) Record Boiler Water Temperature																															
(3) Record Flue Gas Temperature																															
WEEKLY CHECKS (Enter Date)																															
	WEEK 1		WEEK 2		WEEK 3		WEEK 4																								
(1) Observe Flame Condition																															
(2) Observe Circulating Pumps																															
MONTHLY CHECKS (Enter Date)																															
(1) Manual Lift Relief Valve																															
(2) Review Condition of or Test Each Item	(A) Flame Detection Devices			(F) Refractory																											
	(B) Limit Controls			(G) Stop Valves																											
	(C) Operating Controls			(H) Check Valves																											
	(D) Floor Drains			(I) Drain Valves																											
	(E) Fuel Piping			(J) Linkages																											
(3) Observe Gage Glass on Expansion Tank																															
(4) Combustion Air Adequate/Unobstructed																															
General Comments:																															

(Instructions on Reverse)

Figure I-1-2 Exhibit B (Cont'd)

EXHIBIT B (Back)

INSTRUCTIONS

- I. Fill in the name of the building, its location, boiler number, fuel type used, and the year. Name the person to be contacted in an emergency or malfunction.
- II. Daily Checks
 - (1) Record pressure (see ASME Section VI — 10.5.1).
 - (2) Record temperature (see ASME Section VI — 10.5.1).
 - (3) Record the flue-gas temperature. (This should be read with the boiler running and at pressure.)
- III. Weekly Checks (Record the date the test or check was completed.)
 - (1) Observe flame condition.
 - (2) Observe circulating pumps for proper operation.
- IV. Monthly Checks (Record the date the test or check was completed.)
 - (1) Lift try lever to full open and release it to snap shut (see ASME Section VI — 6.8).
 - (2) Review the condition of or test each item per Manufacturer's instructions.
 - (A) Test flame-detection devices.
 - (B) Test limit controls.
 - (C) Test operating controls.
 - (D) Test floor drains to be sure they are draining properly.
 - (E) Check fuel piping for leakage.
 - (F) If possible without opening boiler, check the refractory for cracking and deterioration.
 - (G) Check stop valves.
 - (H) Inspect check valves.
 - (I) Check drain valves.
 - (J) Check linkages for damage or disconnection.
 - (3) Observe water level of gage glass on expansion tank. (Optional.)
 - (4) Check combustion air supply for obstructions and adequacy of airflow.
- V. Log Retention

Retain this log for at least 1 year (see ASME Section VI — 5.13).

2021 ASME Boiler and Pressure Vessel Code

AN INTERNATIONAL CODE

The ASME Boiler and Pressure Vessel Code (BPVC) is a globally recognized and trusted source of technical requirements and guidance for the design and construction of boilers, pressure vessels, and nuclear components. With each new edition, the Code continues to evolve, introducing new technologies and processes to promote safety across pressure equipment applications and disciplines. Developed through a rigorous consensus process and fueled by the foresight of leading industry experts from around the world, the ASME BPVC is an ever-evolving set of standards that meets the needs of a changing world.

ASME provides BPVC users with an integrated suite of related offerings, which includes

- referenced standards
- related standards and guidelines
- conformity assessment programs
- learning and development solutions
- ASME Press books and journals



For additional information and to order:

Phone: 1.800.THE.ASME

(1.800.843.2763)

Email: customercare@asme.org

Website: go.asme.org/bpvc

ISBN 978-0-7918-7421-9



9 7 8 0 7 9 1 8 7 4 2 1 9



3 0 0 0 6 0